

FNC1

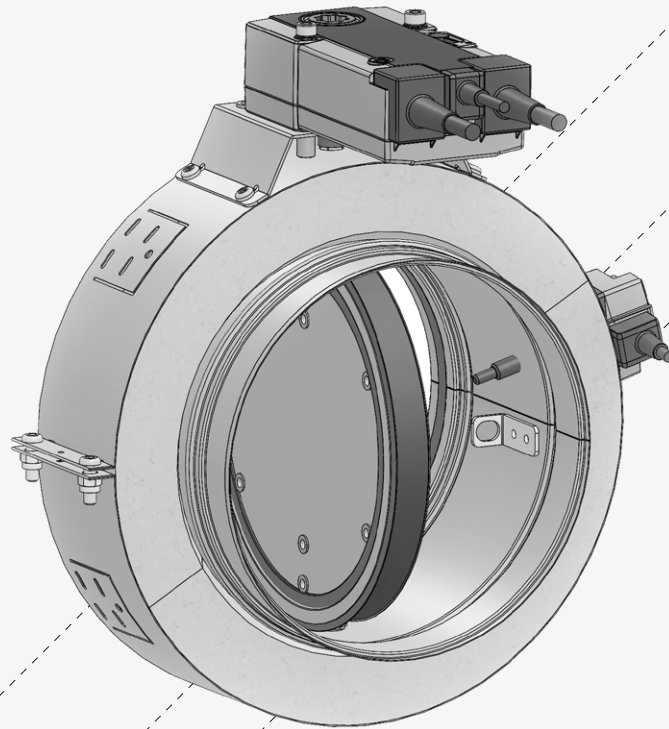

Technical Manual
English

FIRE DAMPER

CIRCULAR SERIES FNC1 - 300 Pa

Cert. N° 1812-CPR-1639
Installation type with fire resistance class



This is a 42 page manual.

1. Overview	p. 4
1.1. Description	p. 4
1.2. General characteristics	p. 4
1.3. European Standards applied	p. 4
1.4. Certifications and approvals	p. 4
1.5. Components	p. 4
1.6. Available dimensions	p. 4
1.7. Performances	p. 5
1.8. Fire resistance classification according to EN 13501-3-2009	p. 5
1.9. Mechanism type	p. 7
2. Technical data	p. 8
2.1. Dimension	p. 8
2.2. Weights	p. 8
3. Installation	p. 9
3.1. Intended use	p. 9
3.2. Not allowed uses	p. 9
3.3. Positioning brackets before fixing	p. 9
3.4. Blade rotation axis positioning	p. 9
3.5. Installation of flexible connectors in order to balance out the ventilation ducts expansion	p. 9
3.6. Transfer Application (application not connected to air ducts on one or both sides)	p. 11
3.7. Minimum distances	p. 13
3.8. Construction supports characteristics	p. 14
3.9. Installations within vertical rigid wall	p. 15
3.10. Installations within vertical light wall (plasterboard)	p. 17
3.11. Installations within floor	p. 20
3.12. Installation remote from the rigid wall	p. 21
3.13. Installation remote from the vertical light wall (plasterboard)	p. 24
3.14. Installations remote from the floor	p. 27
4. Electrical connections	p. 28
4.1. Electrical wiring	p. 28
4.2. Electrical specifications	p. 29
5. Maintenance and inspections	p. 30
5.1. Periodic inspection and cleaning	p. 30
5.2. Repair	p. 30
5.3. Disposal	p. 30
6. Selection	p. 31
6.1. Air flow rates in relation to the diameter	p. 31
6.2. Air flow rates as a function of the pressure drop	p. 31
6.3. Air flow rates as a function of generated sound levels	p. 31
6.4. Pressure drop and sound level graph	p. 32
6.5. Sound spectrum table	p. 33
7. Accessories and spare parts	p. 35
8. How to order	p. 37
8.1. Motorized fire dampers	p. 37
8.2. Fire dampers	p. 37
8.3. Electric motor driven actuators	p. 37
9. Specification Text	p. 38
9.1. Series FNC1 circular fire damper	p. 38
10. Revision Index	p. 39

1. OVERVIEW

1.1. Description

Fire dampers FNC1 are devices for use in heating, ventilation and air-conditioning (HVAC) systems at fire boundaries to maintain compartmentation and protect means of escape in case of fire. They satisfy integrity, insulation and smoke leakage criteria for the declared time of fire resistance.

Tested and classed in accordance with EN 1366-2 and EN 13501-3 regulations with 300 Pa depression.

Studied and optimized for small diameter ducts and reduced installation space focusing on aerualic and acoustical performance.

1.2. General characteristics

- Casing made from galvanized carbon steel.
- Air duct connection gasket Lindab Safe.
- Damper blade 20 mm thick made from refracting material
- Lip seal on blade border for cold smoke seal.
- Internal intumescent gasket for hot smoke seal.

1.3. European Standards applied

CE certification	EN 15650
Test	EN 1366-2
Classification	EN 13501-3
Thermal fuse reliability	ISO 10294-4
Air tightness	EN 1751
Resistance to corrosive environments	EN 60068-2-52

1.4. Certifications and approvals

CE Certificate of Constancy of Performance	n° 1812-CPR-1639	Efectis
RISE Approval (Sweden)	n° C001171	RISE

1.5. Components

- | | |
|--|-------------------------------|
| 1. Metal external protection ring | 5. Air duct connection gasket |
| 2. Refractory external protection ring | 6. Damper blade |
| 3. Motor support | 7. Thermal fuse |
| 4. Servomotor | |

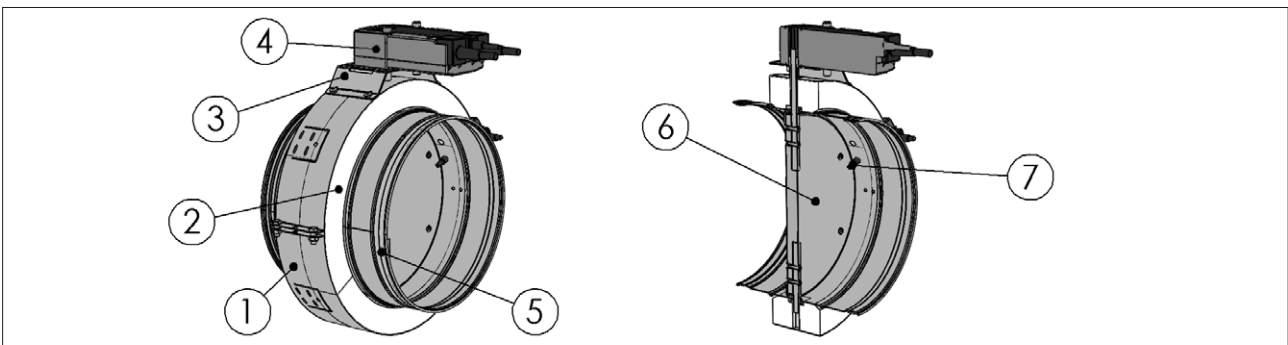

1.6. Available dimensions

Ø	mm	100	125	160	200	250	315	400
---	----	-----	-----	-----	-----	-----	-----	-----

1.7. Performances

Performance	Reference standard	Class
Thermal fuse testing	ISO 10294-4	Compliant
Open and Close cycle reliability	EN 15650	Compliant
Resistance to corrosion in humid and saline environments	EN 60068-2-52	Degree of severity 2
Casing tightness	EN 1751	Class C
Blade seal	EN 1751	Class 4

1.8. Fire resistance classification according to EN 13501-3-2009

Rigid wall		EI 60 S (300 Pa)	EI 30 S (300 Pa)
EI 60S Installation within vertical rigid wall hole Ø+30 p. 15			
Wall minimum thickness 95 mm		Ø	Ø
Wall minimum resistance class EI 60			
Mortar or plaster putty or rock wool 35 kg/m ³ density sealing ve (i↔o)	D/W	min 100 max 400	min 100 max 400
EI 60S Installation within vertical rigid wall hole Ø+10 p. 16			
Wall minimum thickness 95 mm		Ø	Ø
Minimum resistance class EI 60			
Acrylic sealant sealing ve (i↔o)	D	min 100 max 400	min 100 max 400
Flexible wall			
		EI 60 S (300 Pa)	EI 30 S (300 Pa)
Installations within vertical light wall EI 60 S hole Ø+30 p. 18			
Wall minimum thickness 95 mm		Ø	Ø
Wall rock wool density up to 35 kg/m ³ (optional)			
Studs made of steel or timber			
mortar or plaster putty or rock wool 35 kg/m ³ and acrylic sealant sealing ve (i↔o)	D/W	min 100 max 400	min 100 max 400
Installations within vertical light wall EI 60 S hole Ø+10 p. 19			
Wall minimum thickness 95 mm		Ø	Ø
Wall rock wool density up to 35 kg/m ³ (optional)			
Studs made of steel or timber			
Acrylic sealant sealing ve (i↔o)	D	min 100 max 400	min 100 max 400
Floor			
		EI 60 S (300 Pa)	EI 30 S (300 Pa)
Installation within floor p. 20			
Floor minimum thickness 100 mm		Ø	Ø
Floor minimum density 550 kg/m ³			
Mortar or plaster putty or rock wool 35 kg/m ³ sealing ho (i↔o)	D/W	min 100 max 400	min 100 max 400

Ø is the minimum and maximum nominal diameter of fire dampers in mm

ve Vertical installation
 ho Horizontal installation
 (i↔o) Origin of fire irrelevant
 Pa Pascal of depression
 E Integrity
 I Thermal insulation
 S Smoke seal
 W Wet method sealing
 D Dry method sealing

Cert. N° 1812-CPR-1639

1.8.1. Installation remote from construction support

Rigid wall			
		EI 60 S (300 Pa)	EI 30 S (300 Pa)
EI 60 S Installation remote from the vertical rigid wall hole Ø+30 p. 22			
Wall minimum thickness 95 mm		Ø	Ø
Wall minimum resistance class EI 60		min 100	min 100
Mortar or plaster putty or rock wool 35 kg/m ³ density sealing	D/W	max 400	max 400
ve (i↔o)			
EI 60S Installation remote from the vertical rigid wall hole Ø+10 p. 23			
Wall minimum thickness 95 mm		Ø	Ø
Minimum resistance class EI 60	D	min 100	min 100
Acrylic sealant sealing		max 400	max 400
ve (i↔o)			
Flexible wall			
		EI 60 S (300 Pa)	EI 30 S (300 Pa)
EI 60 S Installation remote from the vertical light wall hole Ø+30 p. 25			
Wall minimum thickness 95 mm		Ø	Ø
Wall rock wool density up to 35 kg/m ³ (optional)		min 100	min 100
Studs made of steel or timber	D/W	max 400	max 400
mortar or plaster putty or rock wool 35 kg/m ³ and acrylic sealant sealing			
ve (i↔o)			
EI 60 S Installation remote from the vertical light wall hole Ø+10 p. 26			
Wall minimum thickness 95 mm		Ø	Ø
Wall rock wool density up to 35 kg/m ³ (optional)		min 100	min 100
Studs made of steel or timber	D	max 400	max 400
Acrylic sealant sealing			
ve (i↔o)			
Floor			
		EI 60 S (300 Pa)	EI 30 S (300 Pa)
Installations remote from the floor p. 27			
Floor minimum thickness 100 mm		Ø	Ø
Floor minimum density 550 kg/m ³		min 100	min 100
Mortar or plaster putty or rock wool 35 kg/m ³ sealing	D/W	max 400	max 400
ho (i↔o)			

Ø is the minimum and maximum nominal diameter of fire dampers in mm

ve Vertical installation
 ho Horizontal installation
 (i↔o) Origin of fire irrelevant
 Pa Pascal of depression
 E Integrity
 I Thermal insulation
 S Smoke seal
 W Wet method sealing
 D Dry method sealing

Cert. N° 1812-CPR-1639

1.9. Mechanism type

1.9.1. Manual and compact manual

Not available

1.9.2. Belimo motorized version

1. Blade locking lever
2. Position indicator
3. Hex key for manual opening
4. Manual closing switch

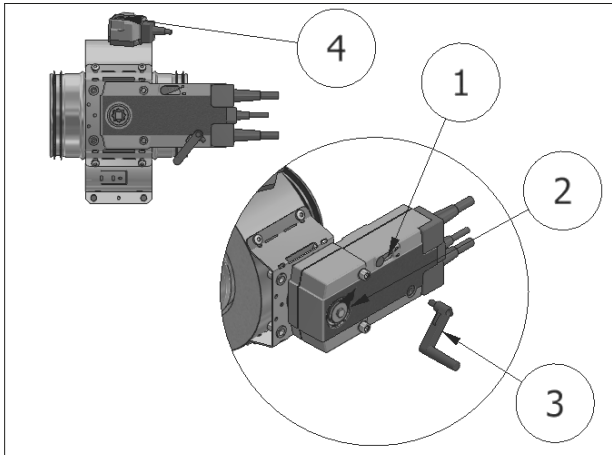

Blade closing mode

Automatic closing with thermal fuse.

The control mechanism has a thermosensitive element that automatically closes the blade when the temperature in the duct or in the room exceeds 72°C (or 95°C for the 95°C version).

To close the damper when the motor is connected, press the switch on the temperature sensor or cut off the power supply.

Blade opening mode

Make sure that the damper is open before the ventilation system start-up, otherwise there is a risk of product malfunction.

To open the damper with the electric motor driven actuator, provide power supply to the motor. Refer to the section Electrical connections [p. 28](#) for further information.

To manually open the damper, use the handle supplied and carefully rotate clockwise to the 90° indicator. To hold the damper in open position operate on the lever indicated in figure.

During the manual opening of the damper, power must not be supplied to the motor.

Position indication microswitches

The motorized versions are supplied with two microswitches to show the blade's position (open or closed). Refer to the section Electrical connections [p. 28](#) for further information.

Closing by remote control

If power to the motor is cut off, the blade will close.

Temperature calibration of thermosensitive element for automatic damper closing

72 °C±7 °C (Standard)

95 °C±9 °C (On request).

1.9.3. Siemens motorized version

1. Position indicator
2. Screwdriver
3. Hex key for manual opening
4. Manual closing switch

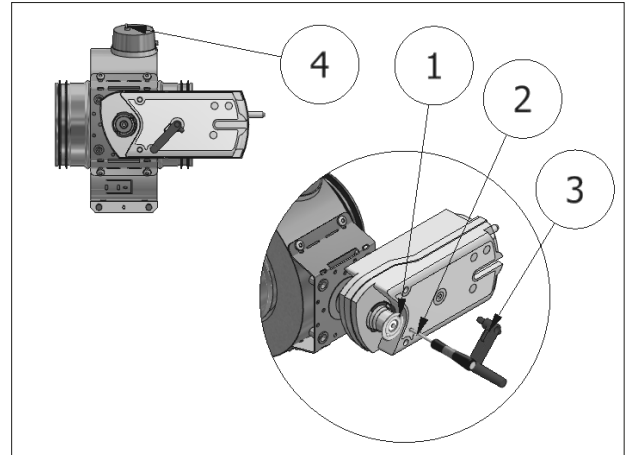

Blade closing mode

Automatic closing with thermal fuse.

The control mechanism has a thermosensitive element that automatically closes the blade when the temperature in the duct or in the room exceeds 72°C (or 95°C for the 95°C version).

To close the damper when the motor is connected, press the switch on the temperature sensor or cut off the power supply.

Blade opening mode

Make sure that the damper is open before the ventilation system start-up, otherwise there is a risk of product malfunction.

To open the damper with the electric motor driven actuator, provide power supply to the motor. Refer to the section Electrical connections [p. 28](#) for further information.

To manually open the damper, use the handle supplied and carefully rotate counterclockwise to the 90 °C indicator. To hold the damper in open position, rotate the screw anticlockwise as shown in the picture.

During the manual opening of the damper, power must not be supplied to the motor.

Position indication microswitches

The motorized versions are supplied with two microswitches to show the blade's position (open or closed). Refer to the section Electrical connections [p. 28](#) for further information.

Closing by remote control

If power to the motor is cut off, the blade will close.

Temperature calibration of thermosensitive element for automatic damper closing

72 °C±7 °C (Standard)

95 °C±9 °C (On request).

2. TECHNICAL DATA

The sizes shown are in mm.

2.1. Dimension

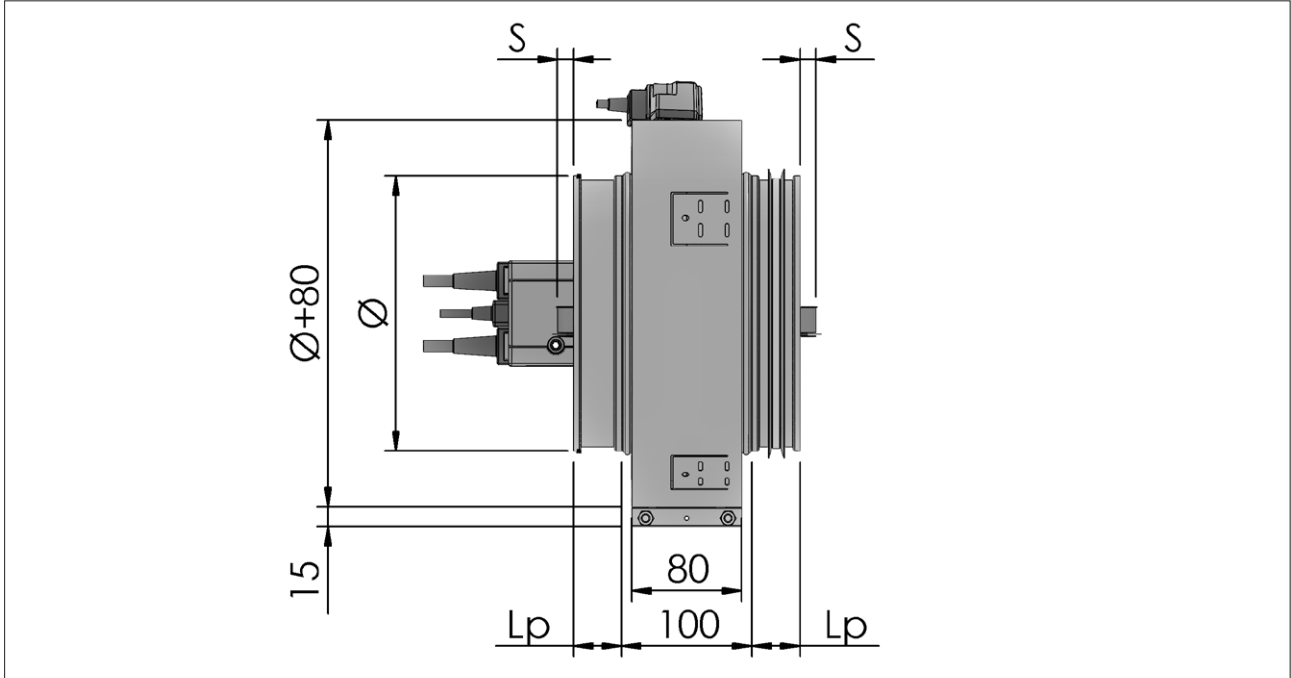

Ø	mm	100	125	160	200	250	315	400
S blade exposition	mm	0	0	0	30	40	80	157
Lp	mm	40	40	40	40	60	60	80

Lp Overlap length between fire damper and duct

2.1.1. Siemens motorized version

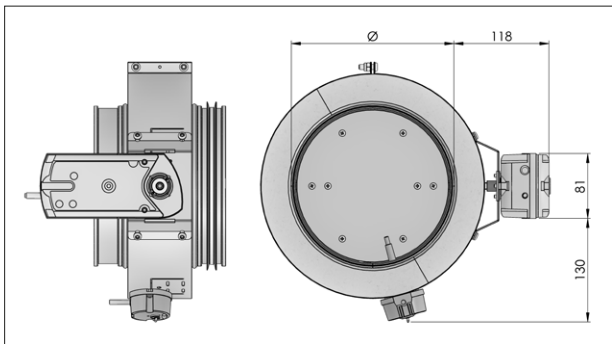

2.1.2. Belimo motorized version

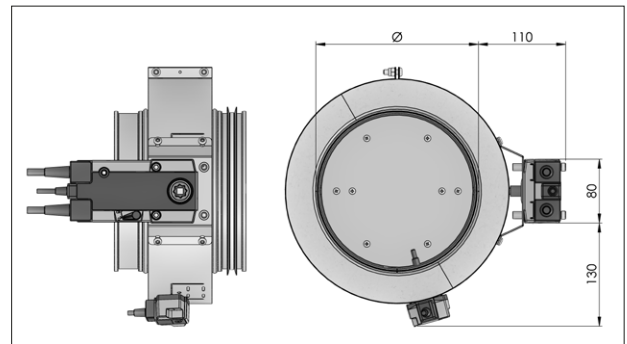

2.2. Weights

Ø	mm	100	125	160	200	250	315	400
Weight	kg	2,9	3,2	3,7	4,5	5,4	6,7	8,2

Manual version. Motorized version: +1 kg

3. INSTALLATION

The sizes shown are in mm.

It is recommended to perform a functional test before installation to exclude possible damage during transport and another test immediately after installation to exclude accidental damage to the product and interference with mounting components.

3.1. Intended use

The MP3 fire dampers are "Devices for use in heating, ventilation and air conditioning (HVAC) systems at fire boundaries to maintain compartmentation and protect means of escape in case of fire" according to the 3.1 paragraph of EN 15650:2010 standard.

It is compulsory to install the fire damper according to the instructions indicated in the technical data sheet and manual to maintain the declared performances and, in particular, the fire classes.

The double test (with the mechanism inside and outside the fire area) demonstrated that there is no preferred direction for the position of the damper, both in relation to air flow and the side with the higher probability of exposure to fire, as indicated in standard EN1366-2:2015 (paragraph 6.2).

Use permitted in any civil and industrial building.
Use permitted in saline atmosphere, for example:

- maritime and port environments;
- fish markets;
- slaughterhouses;
- cheese makers.

3.2. Not allowed uses

- Use with installations different to those described in the technical data sheet and manual;
- use as smoke control damper;
- use in external environments without adequate protection from atmospheric conditions;
- use in explosive environments;
- use on board of ships;
- use in cooker extraction hoods;
- use in pneumatic conveying systems of dust or corn;
- use in ventilation systems within locations subject to chemical contamination;
- use in non inspectable environments;
- installation in fire resistant false ceilings crossings;
- use in ventilation ducts where condensation can occur.

3.3. Positioning brackets before fixing

1. Positioning brackets

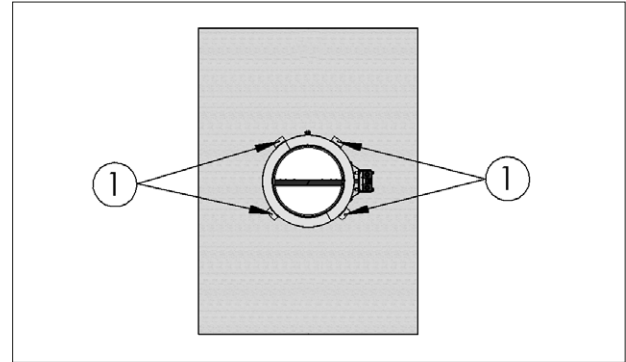

3.4. Blade rotation axis positioning

The fire damper can be installed with the blade axis positioned vertically or horizontally or tilted at any angle.

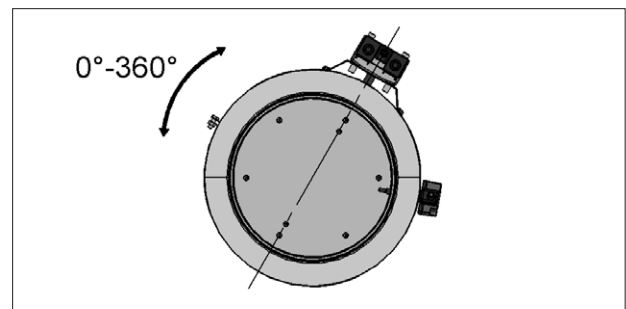

3.5. Installation of flexible connectors in order to balance out the ventilation ducts expansion

ATTENTION: the following indications must be considered binding only if legislation or local regulation where the fire dampers are installed require the use of flexible connectors.

Flexible connectors compensate any duct thermal expansion and wall bending in case of fire.

Flexible connectors are used to limit fire damper stresses due to external forces in case of fire and to preserve fire resistance class.

In general it is always appropriate the use of flexible connectors for the followings installations:

- light walls;
- Plasterboard and rock wool or Fire Batt (Weichschott) sealing;
- Applique fixing system.

Flexible connector must be normal flammability and in case of fire the grounding bonding should disconnect to guarantee the complete separation between fire damper and connected air duct.

When flexible connectors made of conductive material (e.g. aluminum) are used, no additional grounding bonding is required.

Despite flexible connector installation, the fire damper must be installed in the construction support so that its weight does not affect damper's installation position both during normal operation and in case of fire.

It is recommended not to compress flexible connectors in the installation phase.

Flexible connector must be at least 100mm long and in order that possible duct thermal expansions are balanced. Take care that the flexible connector does not interfere with opening / closing movement of the blade.

Refer to the section Technical data [p. 8](#) for blade exposition values.

3.6. Transfer Application (application not connected to air ducts on one or both sides)

Note: For this application please refer to national legislation to verify if any specific obligation is required.

Following tests performed as per EN 1366-2, section 6.3.6 Standard, it is possible to install the fire damper free from air duct from one or both sides.

- Attention: fire resistance classification for transfer application is conform to section Fire resistance classification according to EN 13501-3-2009 [p. 5](#)
- End cap with mesh shall be mounted on the side not connected to air duct.
- End cap with mesh is made from galvanized steel sheet.
- End cap with mesh is supplied not installed on the fire damper.
- Refer to the section How to order (transfer Application) [p. 12](#) for codes to use.

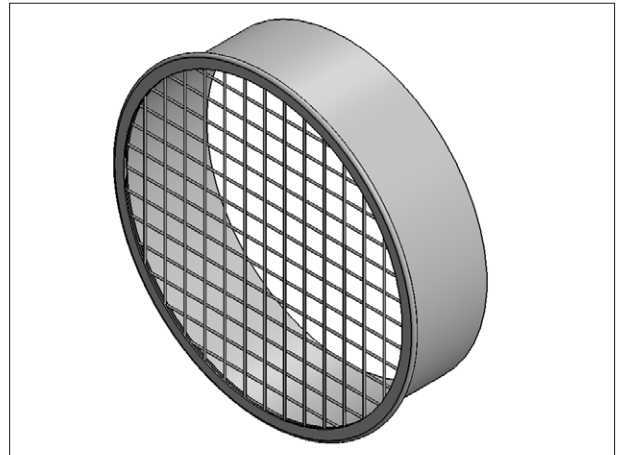

3.6.1. Components (Transfer Application)

1. End cap with mesh (to fix to fire damper with steel screws)

2. Fire damper

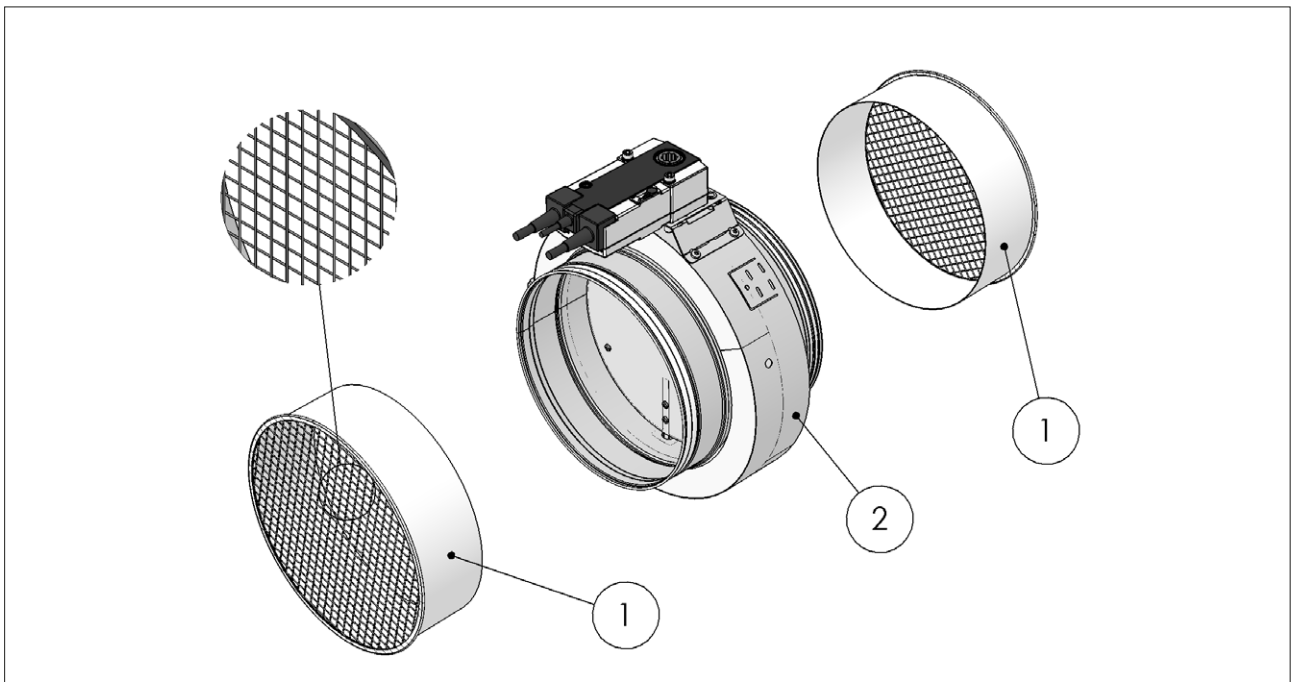

3.6.2. Technical data (Transfer Application)

1. End cap with mesh

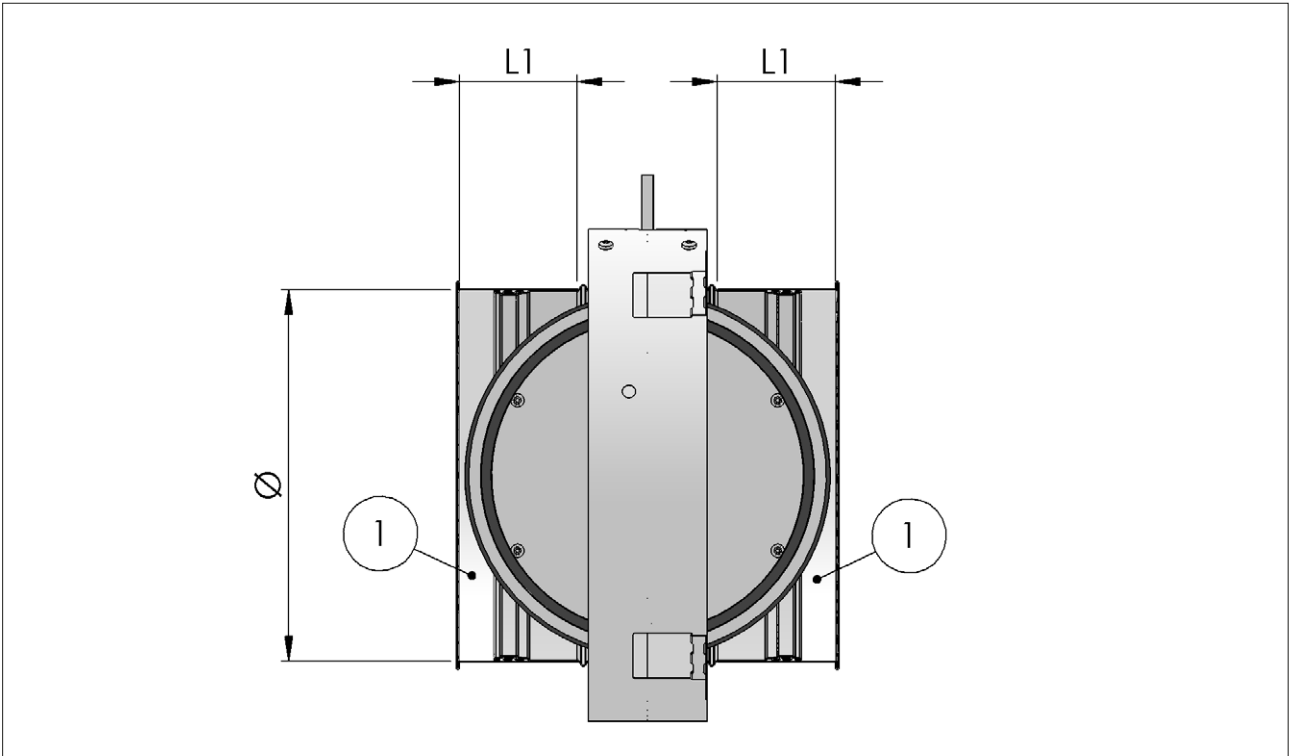

Length of end cap with mesh depending on fire damper diameter Ø.

Ø mm	L1 mm
100	50
125	60
160	80
200	100
250	130
315	160
400	200

Ø Fire damper nominal diameter
L1 End cap length mechanism side

3.6.3. How to order (transfer Application)

Code		
Type	EPNF	End cap with mesh
Diameter	XYZ	Nominal diameter dimension (mm)
Length	XYZ	Length dimension (mm)
Examples		Code
End cap with mesh length 50 mm for fire damper Ø100		EPNF10050
End cap with mesh length 100 mm for fire damper Ø200		EPNF200100

The code refers to the single piece and not to the couple

3.7. Minimum distances

It is recommended to keep enough space (about 200mm) for using or replacing the control mechanism or for maintenance. Also provide the necessary space to remove the ventilation duct from the damper whenever necessary.

In accordance with Articles 7 and 13 of EN 1366-2 respect the minimum distances indicated below.

1. Vertical lateral wall

2. Floor

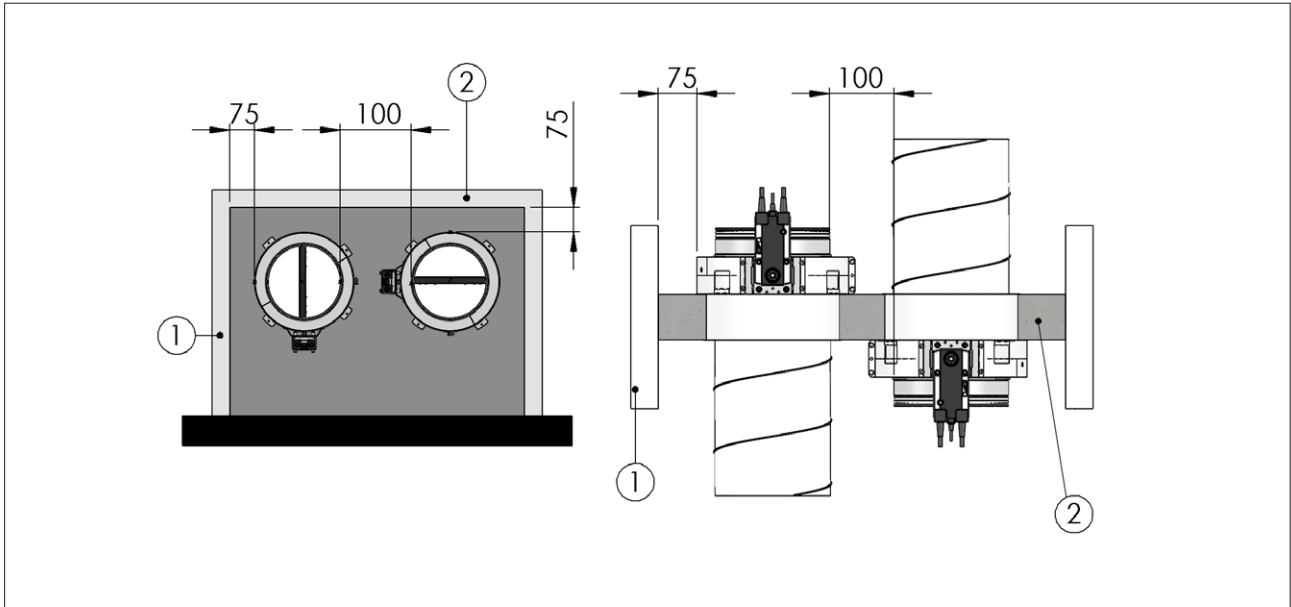

3.7.1. Minimum distances for remote installation from vertical wall/floor

1. Side wall/ floor

2. Construction supports (floor/ wall)

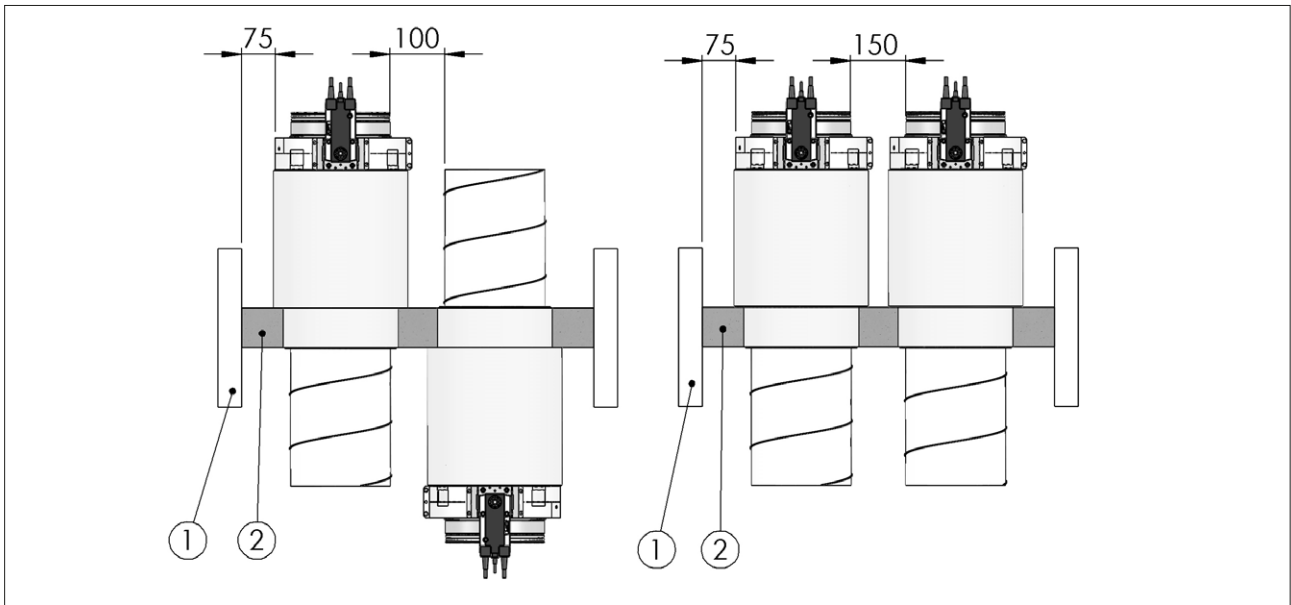

3.8. Construction supports characteristics

The European standard for fire dampers foresees a precise correlation between the wall/floor characteristics and the fire resistance class obtained, as well as the correlation between wall/floor used for the test and wall/floor used for the actual installation.

The test results obtained on a type of wall/floor are valid also for walls/floor of the same type but with greater thickness and/or density than those used in the test.

For plasterboard walls, the test results are also valid for walls with a greater number of plasterboard layers on each side. As a result, the indicated thickness and density characteristics are to be considered as minimum values.

The wall/floor in which the fire dampers are installed must be fire resistance classified according to the standards foreseen for the structure.

3.8.1. Rigid walls

Can be made with aerated concrete blocks, poured concrete, concrete panels, perforated cell elements in concrete or brick in accordance with the following characteristics:

- minimum thickness 95 mm;
- Wall minimum resistance class EI 60.

The use of a reinforcing beam above the opening is recommended for walls made from concrete blocks, bricks or in concrete cell elements.

For walls built with perforated elements, it is also recommended that the area of the opening be made from full elements (for example aerated concrete blocks) to guarantee the correct adhesion of the mortar.

1. Reinforcing beam

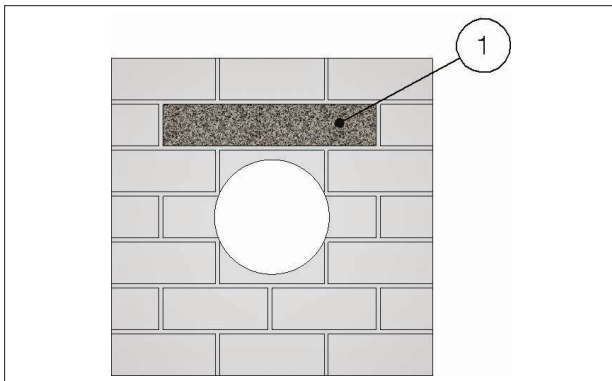

3.8.2. Light plasterboard vertical walls

During testing, light plasterboard walls have been used with the following characteristics:

- U-shaped horizontal metal frame 45mm and C-shaped vertical frame 44mm made from 0,6 mm thick metal sheet, or timber 45x45mm;
- vertical profiles placed with a maximum spacing of 1000 mm;
- Filling made of rock wool with density up to 35 kg/m³ (optional);
- Each side is made from two plasterboard layers 12,5 mm thick, unalined to avoid alignment between the joints of the layer above and below.

The following indications are given for the installation walls:

- metal profiles minimum width: 44 mm;

- metal profiles minimum thickness: 0,6 mm, or timber studs minimum section 45 x 45mm;
- vertical profiles placed with a maximum spacing of 1000 mm between each other;
- vertical profile fixing with selfthreading screws or by clinching to the bottom horizontal profile and insertion in the top horizontal profile;
- profiles fixed using self-threading screws or by clinching on every intersection.
- Filling made of rock wool with density up to 35 kg/m³ (optional);
- each side is made from two plasterboard layers 12,5 mm minimum thick, unalined to avoid alignment between the joints of the layer above and below.
- the front plasterboards layers are fixed using long enough screws to pass through the lower plasterboard and attach to the steel profile underneath.

1. Plasterboard thickness 12,5 mm
2. Rock wool density up to 35 kg/m³ (optional)
3. Horizontal U-shaped profile
4. Vertical C-shaped profile
5. Self-drilling screw Ø 3,5 X 25 mm
6. Self-drilling screw Ø 3,5 X 35 mm
7. Timber studs 45x45 mm or 44 mm "C" steel stud

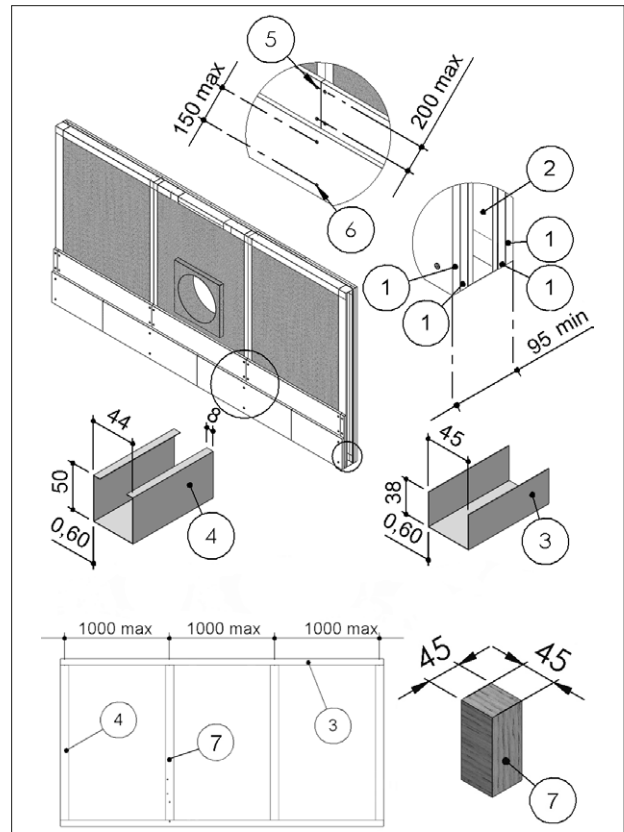

3.8.3. Concrete floors

Aerated concrete floors can be built during installation or with preformed slabs with interlocking shaped edges according to the following characteristics:

- minimum thickness 100 mm;
- minimum density 550 kg/m³.

3.9. Installations within vertical rigid wall

Refer to the section Construction supports characteristics p.14 for further information.

Comply with the minimum distances indicated on section Minimum distances p.13.

Before and after installation please perform a functional test. Refer to section Mechanism type for further information p.7.

3.9.1. Wall opening

A opening must be provided in the wall as indicated in the table and in the drawing

3.9.2. Damper positioning

Position the damper in the opening so that the side of the closing mechanism extends as indicated in the drawing. Close the blade before installing the fire damper.

3.9.3. Filling

Fill the space between the wall and the damper as indicated in the table and in the drawing. Sealing with concrete is not allowed.

	Fire resistance classification	"D" hole size [mm]	Wall minimum thickness "S" [mm]	Sealing
Installations within vertical rigid wall EI 60 S				
Wall resistance class EI 60	EI 60 S (300 Pa)	From Ø + 30 to Ø + 55	95	Rock wool 35 kg/m ³ or mortar or plaster putty and fire stopping sealant (e.g. Soudal Firecryl or equivalent with resistance and reaction to fire equal or higher)
Installations within vertical rigid wall EI 60 S				
Wall resistance class EI 60	EI 60 S (300 Pa)	Ø + 10	95	Fire stopping sealant (reference Soudal Firecryl or equivalent with resistance and reaction to fire equal or higher)

Installations within vertical rigid wall EI 60 S hole Ø+30

1. Positioning brackets
 2. Screw Ø 3,5 X 35 mm or equivalent
 3. Fire damper
 4. Ventilation duct
 5. Rock wool 35 kg/m³, or mortar or plaster putty
 6. Fire stopping sealant (reference Soudal Firecryl or equivalent with resistance and reaction to fire equal or higher) between refractory ring and construction support
 7. Fire stopping sealant (reference Soudal Firecryl or equivalent with resistance and reaction to fire equal or higher) to cover the sealing
- D Hole size: see table above

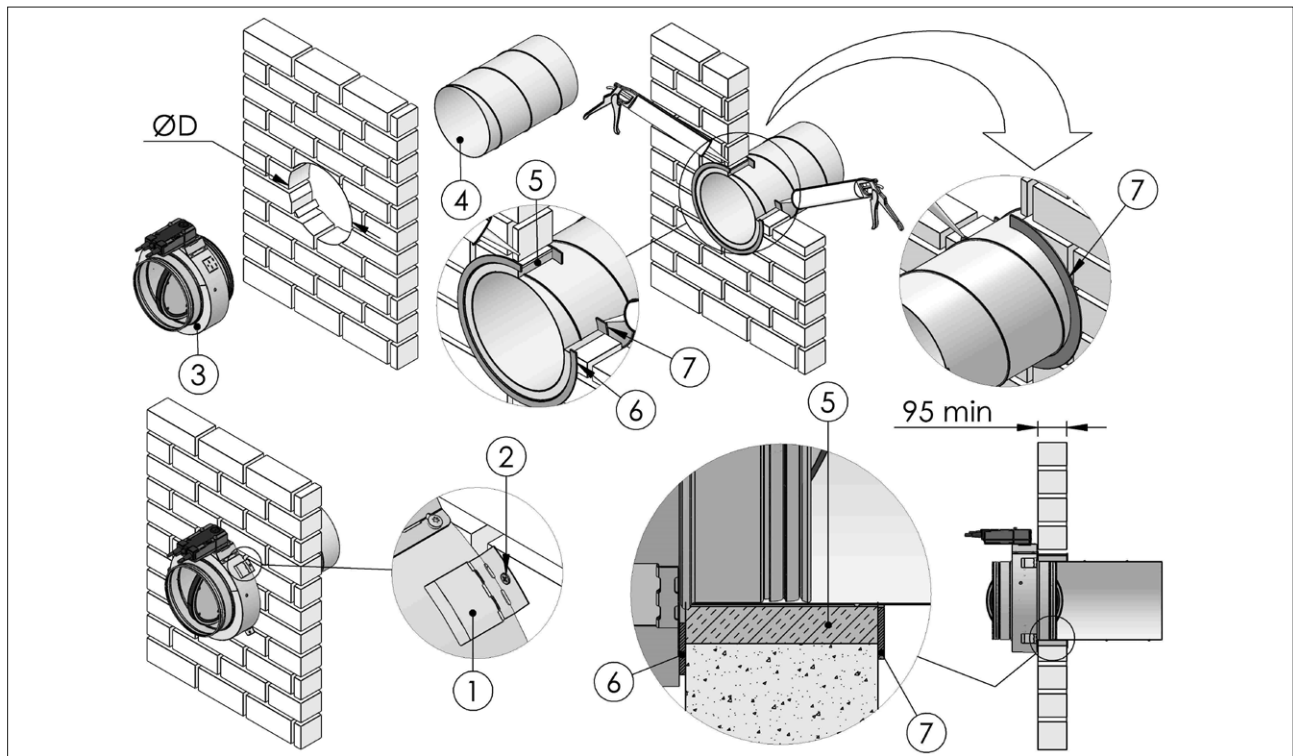

Installations within vertical rigid wall EI 60 S hole Ø+10

- | | |
|--|--|
| 1. Positioning brackets | 6. Fire stopping sealant (reference Soudal Firecryl or equivalent with resistance and reaction to fire equal or higher) between refractory ring and construction support |
| 2. Screw Ø 3,5 X 35 mm or equivalent | 7. Self-drilling screw Ø3,5 X 25 mm |
| 3. Fire damper | D. Hole size: see table above |
| 4. Ventilation duct | |
| 5. Corner support (es. TS11/TS12 Lindab) | |

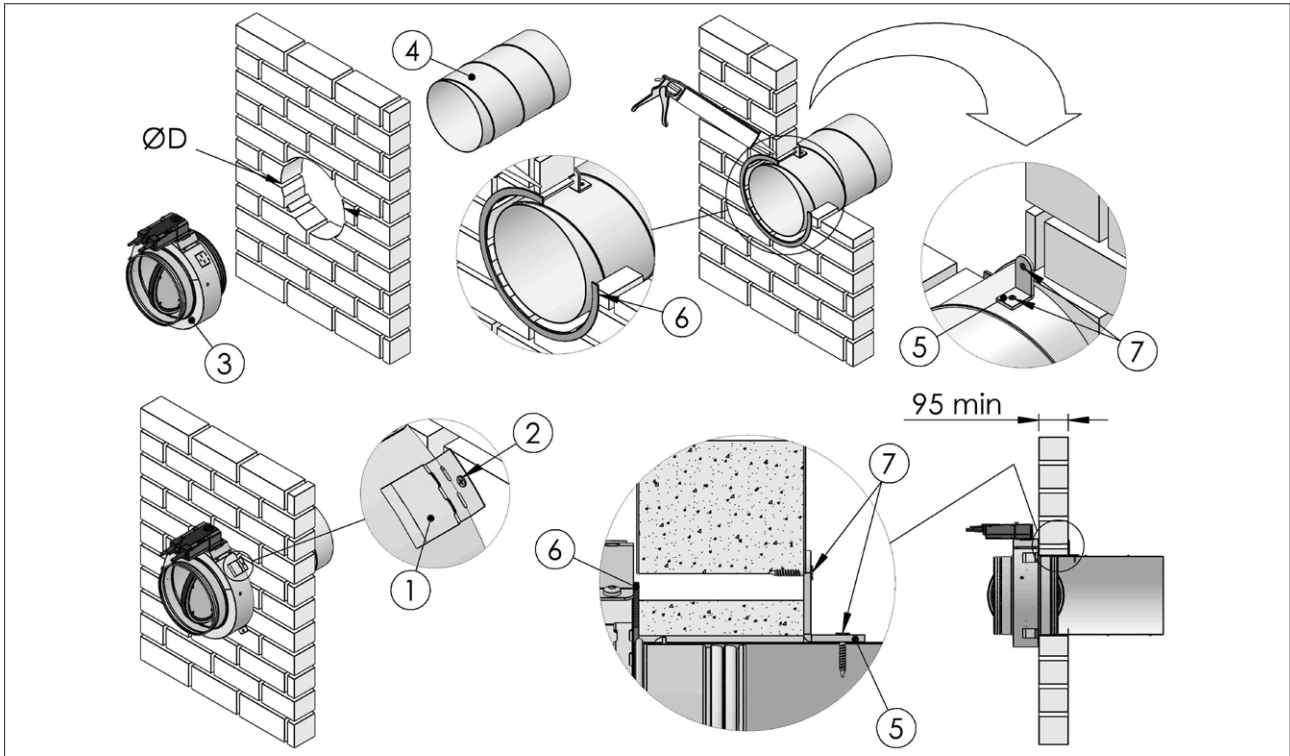

3.10. Installations within vertical light wall (plasterboard)

Refer to the section Construction supports characteristics [p.14](#) for further information.

Comply with the minimum distances indicated on section Minimum distances [p.13](#).

Before and after installation please perform a functional test. Refer to section Mechanism type for further information [p.7](#).

3.10.1. Wall opening

A opening must be provided in the wall as indicated in the table and in the drawing

3.10.2. Damper positioning

Position the damper in the opening so that the side of the closing mechanism extends as indicated in the drawing. Close the blade before installing the fire damper.

3.10.3. Filling

Fill the space between the wall and the damper as indicated in the table and in the drawing. Sealing with concrete is not allowed.

	Fire resistance classification	"D" hole size [mm]	Wall minimum thickness "S" [mm]	Sealing
Installations within vertical light wall EI 60 S				
Wall resistance class EI 60	EI 60 S (300 Pa)	From $\emptyset + 30$ to $\emptyset + 55$	95	Rock wool 35 kg/m ³ or mortar or plaster putty and fire stopping sealant (e.g. Soudal Firecryl or equivalent with resistance and reaction to fire equal or higher)
Installations within vertical light wall EI 60 S				
Wall resistance class EI 60	EI 60 S (300 Pa)	$\emptyset + 10$	95	Fire stopping sealant (reference Soudal Firecryl or equivalent with resistance and reaction to fire equal or higher)

Installations within vertical light wall EI 60 S hole Ø+30

- | | |
|---|---|
| <ol style="list-style-type: none"> 1. Plasterboard thickness 12,5 mm type A (EN 520) or higher 2. Rock wool density 35 kg/m³ (optional) 3. Fire damper 4. Ventilation duct 5. Rock wool 35 kg/m³, or mortar or plaster putty 6. Fire stopping sealant (reference Soudal Firecryl or equivalent with resistance and reaction to fire equal or higher) between refractory ring and construction support | <ol style="list-style-type: none"> 7. Timber studs 45 x 45 mm or metal frame 8. Positioning brackets 9. Self-drilling screw Ø 3,5 X 35 mm 10. Fire stopping sealant (reference Soudal Firecryl or equivalent with resistance and reaction to fire equal or higher) to cover the sealing <p>D Hole size: see table above</p> |
|---|---|

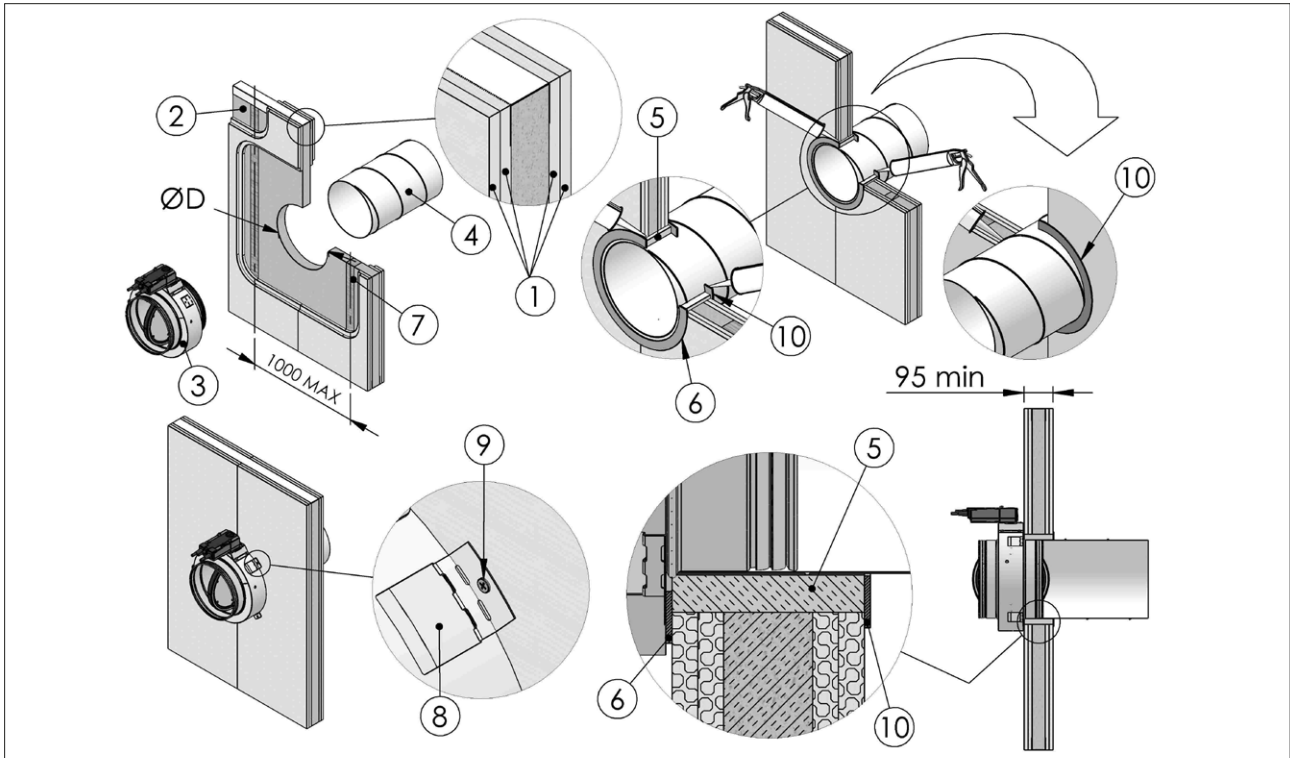

Installations within vertical light wall EI 60 S hole Ø+10

- | | |
|--|---|
| 1. Plasterboard thickness 12,5 mm type A (EN 520) or higher | 7. Timber studs 45 x 45 mm or metal frame |
| 2. Rock wool density 35 kg/m ³ (optional) | 8. Positioning brackets |
| 3. Fire damper | 9. Self-drilling screw Ø 3,5 X 35 mm |
| 4. Ventilation duct | 10. Self-drilling screw Ø 3,5 X 35 mm |
| 5. Corner support (es. TS11/TS12 Lindab) | D. Hole size: see table above |
| 6. Fire stopping sealant (reference Soudal Firecryl or equivalent with resistance and reaction to fire equal or higher) between refractory ring and construction support | |

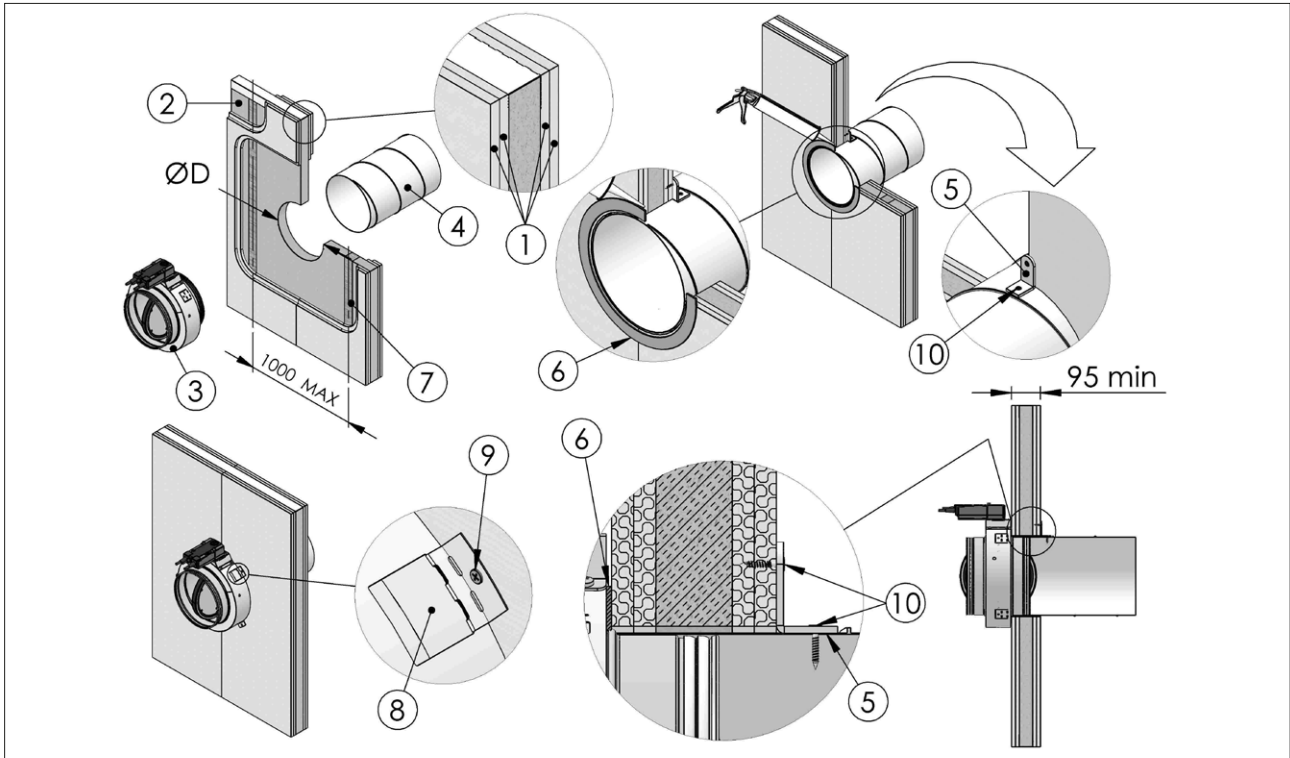

3.11. Installations within floor

Refer to the section Construction supports characteristics [p.14](#) for further information.

Comply with the minimum distances indicated on section Minimum distances [p.13](#).

Before and after installation please perform a functional test. Refer to section Mechanism type for further information [p.7](#).

3.11.1. Floor opening

A opening must be provided in the floor as indicated in the table and in the drawing

1. Positioning brackets
2. Screw $\varnothing 3,5 \times 35$ mm or equivalent
3. Fire damper
4. Ventilation duct
5. Rock wool 35 kg/m³, or mortar or plaster putty

3.11.2. Damper positioning

Position the damper in the opening so that the side of the closing mechanism extends as indicated in the drawing. Close the blade before installing the fire damper.

3.11.3. Filling

Fill the space between the floor and the damper as indicated in the drawing.

Sealing with concrete is not allowed.

6. Fire stopping sealant (reference Soudal Firecryl or equivalent with resistance and reaction to fire equal or higher) to cover the sealing
 7. Fire stopping sealant (reference Soudal Firecryl or equivalent with resistance and reaction to fire equal or higher) between refractory ring and construction support
- D from nominal diameter min + 30 to nominal diameter max + 55

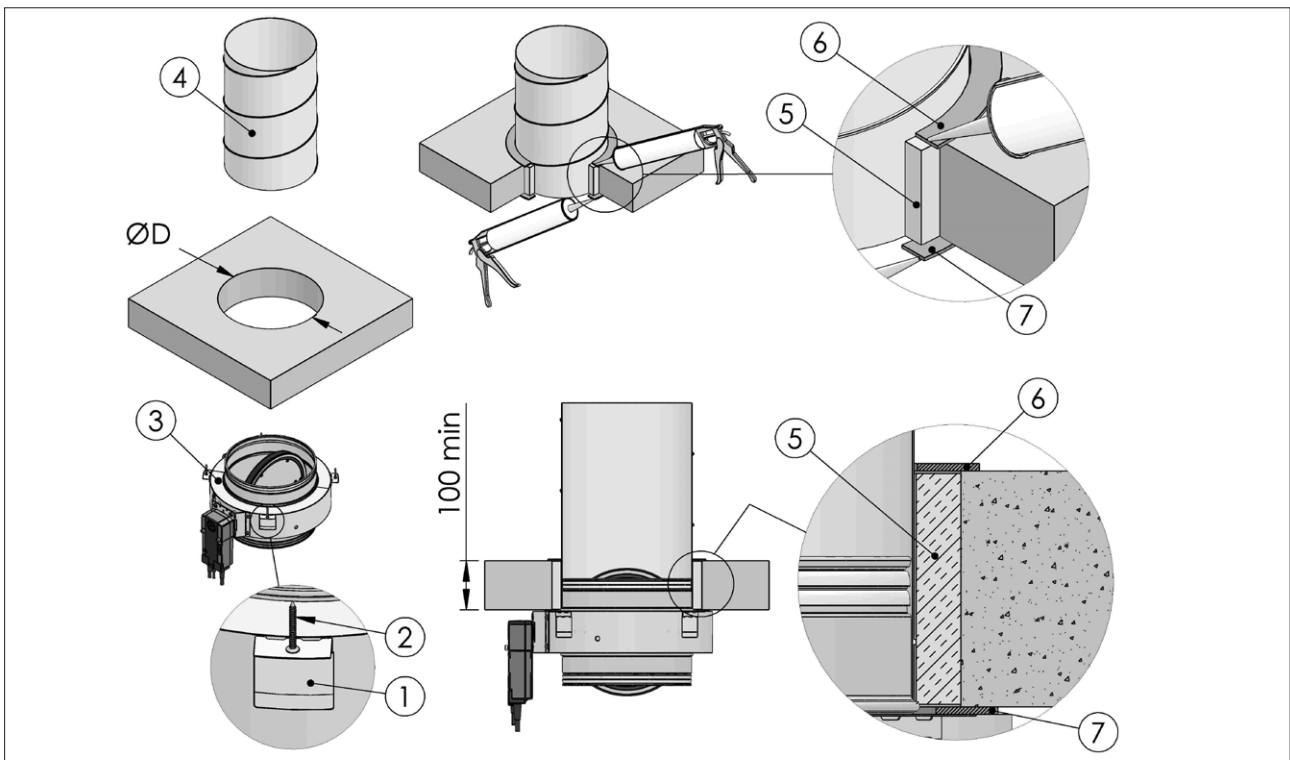

3.12. Installation remote from the rigid wall

Refer to the section Construction supports characteristics [p.14](#) for further information.

Comply with the minimum distances indicated on section Minimum distances [p.13](#).

Before and after installation please perform a functional test. Refer to section Mechanism type for further information [p.7](#).

3.12.1. Wall opening

A opening must be provided in the wall as indicated in the table and in the drawing

3.12.2. Damper positioning

Connect fire damper to the galvanized steel duct as indicated in the drawing.

Install the damper with the mechanism facing away from the wall as indicated in the drawing.

The fire damper has to be fixed and suspended from the ceiling as indicated in the drawing.

For distance between fire damper and wall less than or equal to 1m, only one support is enough as indicated in the drawing.

The support at 20 mm from the fire damper is always mandatory.

Close the blade before installing the fire damper.

3.12.3. Filling

Fill the space between the wall and the damper as indicated in the table and in the drawing.

Sealing with concrete is not allowed.

Cover the duct over its entire length and fire damper as indicated in the drawing wrapping it with insulation rock wool Pro Wired Mat 80 AL 1 Paroc with density of 80 kg/m³ and thickness 70 mm or equivalent.

A metallic mesh is installed around the rock wool. The junctions between the insulation and the damper are made by an acrylic fire stopping sealant (es. Soudal Firecryl or equivalent with resistance and reaction to fire equal or higher), as indicated in the drawing.

	Fire resistance classification	"D" hole size [mm]	Wall minimum thickness "S" [mm]	Sealing
EI 60S Installation remote from the vertical rigid wall				
Wall resistance class EI 60	EI 60 S (300 Pa)	From Ø + 30 to Ø + 55	95	Rock wool 35 kg/m ³ or mortar or plaster putty and fire stopping sealant (e.g. Soudal Firecryl or equivalent with resistance and reaction to fire equal or higher)
EI 60S Installation remote from the vertical rigid wall				
Wall resistance class EI 60	EI 60 S (300 Pa)	Ø + 10	95	Fire stopping sealant (reference Soudal Firecryl or equivalent with resistance and reaction to fire equal or higher)

EI 60 S Installation remote from the vertical rigid wall hole Ø+30

- | | |
|--|--|
| <ol style="list-style-type: none"> 1. Ventilation duct in one piece 2. M8 threaded rod and suspension rings 3. Fire damper 4. Fire stopping sealant (reference Soudal Firecryl or equivalent with resistance and reaction to fire equal or higher) between insulation and sealing 5. Self-drilling screw Ø 4,2 X 13 mm x4 6. Rock wool 35 kg/m³, or mortar or plaster putty 7. Insulation rock wool Pro Wired Mat 80 AL 1 Paroc or equivalent: see Installation remote from the rigid wall p. 21 | <ol style="list-style-type: none"> 8. Fire stopping sealant (reference Soudal Firecryl or equivalent with resistance and reaction to fire equal or higher) between insulation and refractory ring 9. Fire stopping sealant (reference Soudal Firecryl or equivalent with resistance and reaction to fire equal or higher) to cover the sealing <p>D Hole size: see table above
 a 1000mm MAX, n° of threaded rods depending on the length of the duct (use 1 threaded bar for a≤1000 mm)</p> |
|--|--|

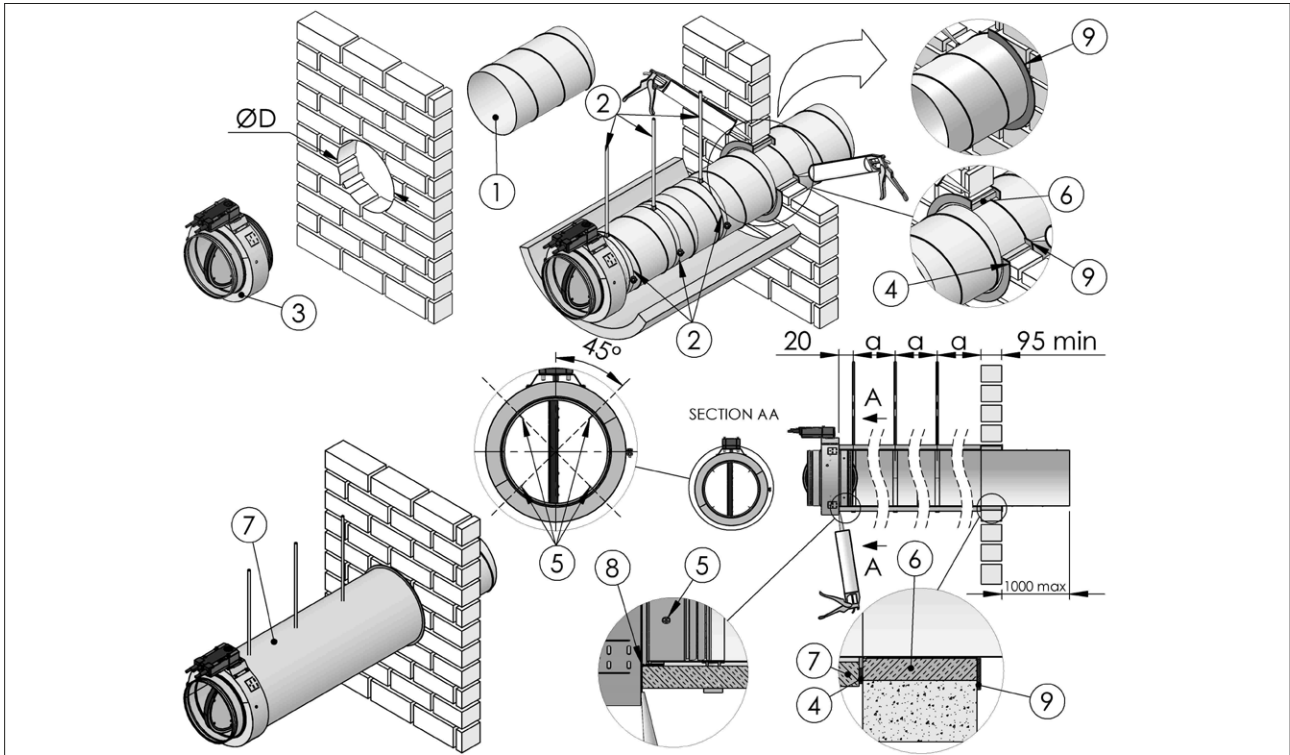

EI 60 S Installation remote from the vertical rigid wall hole Ø+10

- | | |
|---|--|
| <ol style="list-style-type: none"> 1. Ventilation duct in one piece 2. M8 threaded rod and suspension rings 3. Fire damper 4. Fire stopping sealant (reference Soudal Firecryl or equivalent with resistance and reaction to fire equal or higher) between insulation and construction support 5. Self-drilling screw Ø 4,2 X 13 mm x4 | <ol style="list-style-type: none"> 6. Insulation rock wool Pro Wired Mat 80 AL 1 Paroc or equivalent: see Installation remote from the rigid wall p. 21 7. Fire stopping sealant (reference Soudal Firecryl or equivalent with resistance and reaction to fire equal or higher) between insulation and refractory ring <p>D Hole size: see table above</p> <p>a 1000mm MAX, n° of threaded rods depending on the length of the duct (use 1 threaded bar for a ≤ 1000 mm)</p> |
|---|--|

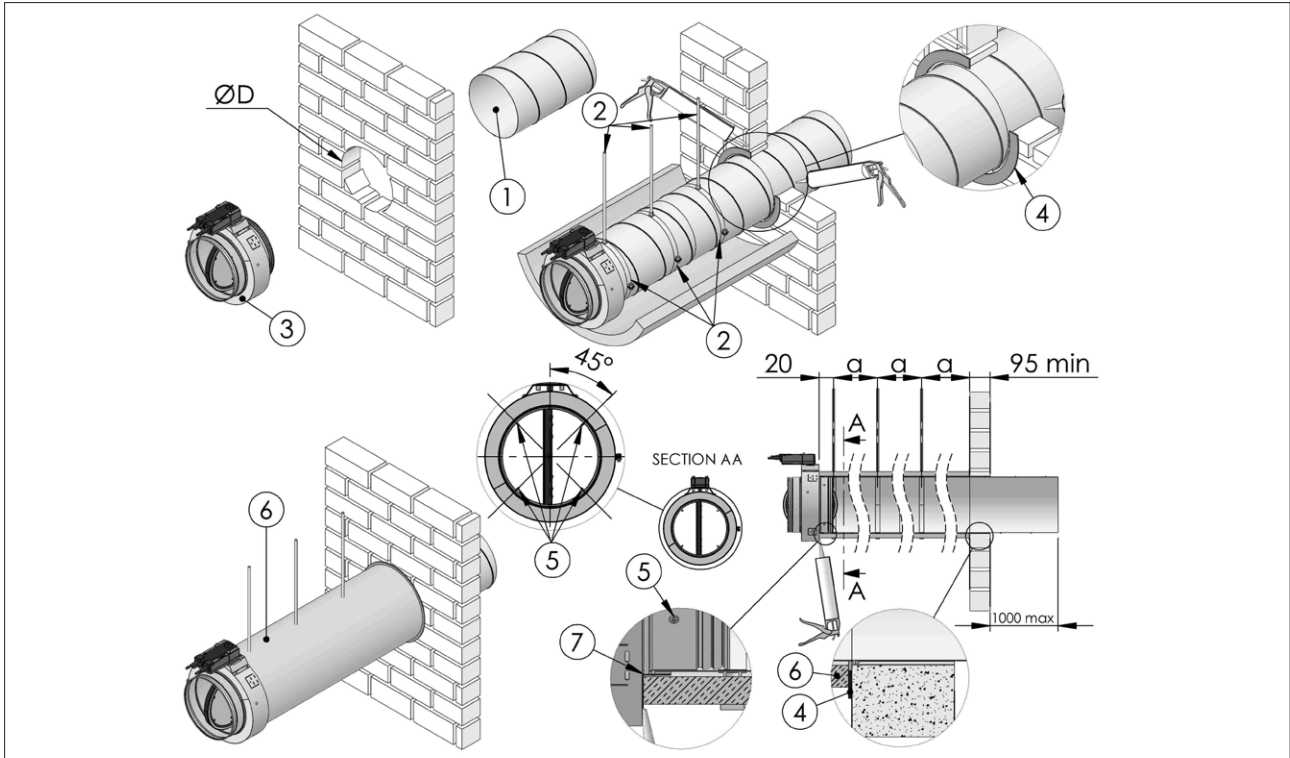

3.13. Installation remote from the vertical light wall (plasterboard)

Refer to the section Construction supports characteristics [p.14](#) for further information.

Comply with the minimum distances indicated on section Minimum distances [p.13](#).

Before and after installation please perform a functional test. Refer to section Mechanism type for further information [p.7](#).

3.13.1. Wall opening

A opening must be provided in the wall as indicated in the table and in the drawing

3.13.2. Damper positioning

Connect fire damper to the galvanized steel duct as indicated in the drawing.

Install the damper with the mechanism facing away from the wall as indicated in the drawing.

The fire damper has to be fixed and suspended from the ceiling as indicated in the drawing.

For distance between fire damper and wall less than or equal to 1m, only one support is enough as indicated in the drawing.

The support at 20 mm from the fire damper is always mandatory.

Close the blade before installing the fire damper.

3.13.3. Filling

Fill the space between the wall and the damper as indicated in the table and in the drawing.

Sealing with concrete is not allowed.

Cover the duct over its entire length and fire damper as indicated in the drawing wrapping it with insulation rock wool Pro Wired Mat 80 AL 1 Paroc with density of 80 kg/m³ and thickness 70 mm or equivalent.

A metallic mesh is installed around the rock wool. The junctions between the insulation and the damper are made by an acrylic fire stopping sealant (es. Soudal Firecryl or equivalent with resistance and reaction to fire equal or higher), as indicated in the drawing.

	Fire resistance classification	"D" hole size [mm]	Wall minimum thickness "S" [mm]	Sealing
EI 60 S Installation remote from the vertical light wall				
Wall resistance class EI 60	EI 60 S (300 Pa)	From Ø + 30 to Ø + 55	95	Rock wool 35 kg/m ³ or mortar or plaster putty and fire stopping sealant (e.g. Soudal Firecryl or equivalent with resistance and reaction to fire equal or higher)
EI 60 S Installation remote from the vertical light wall				
Wall resistance class EI 60	EI 60 S (300 Pa)	Ø + 10	95	Fire stopping sealant (reference Soudal Firecryl or equivalent with resistance and reaction to fire equal or higher)

EI 60 S Installation remote from the vertical light wall hole Ø+30

- | | |
|---|---|
| <ol style="list-style-type: none"> 1. Timber studs 45 x 45 mm or metal frame 2. Rock wool density 35 kg/m³ (optional) 3. Plasterboard thickness 12,5 mm type A (EN 520) or higher 4. Ventilation duct in one piece 5. M8 threaded rod and suspension rings 6. Fire damper 7. Fire stopping sealant (reference Soudal Firecryl or equivalent with resistance and reaction to fire equal or higher) between insulation and sealing 8. Self-drilling screw Ø 4,2 X 13 mm x4 9. Rock wool 35 kg/m³, or mortar or plaster putty | <ol style="list-style-type: none"> 10. Insulation rock wool Pro Wired Mat 80 AL 1 Paroc or equivalent: see Installation remote from vertical light wall (plasterboard) p.24 11. Fire stopping sealant (reference Soudal Firecryl or equivalent with resistance and reaction to fire equal or higher) to cover the insulation 12. Fire stopping sealant (reference Soudal Firecryl or equivalent with resistance and reaction to fire equal or higher) between insulation and refractory ring <p>D Hole size: see table above
 a 1000mm MAX, n° of threaded rods depending on the length of the duct (use 1 threaded bar for a≤1000 mm)</p> |
|---|---|

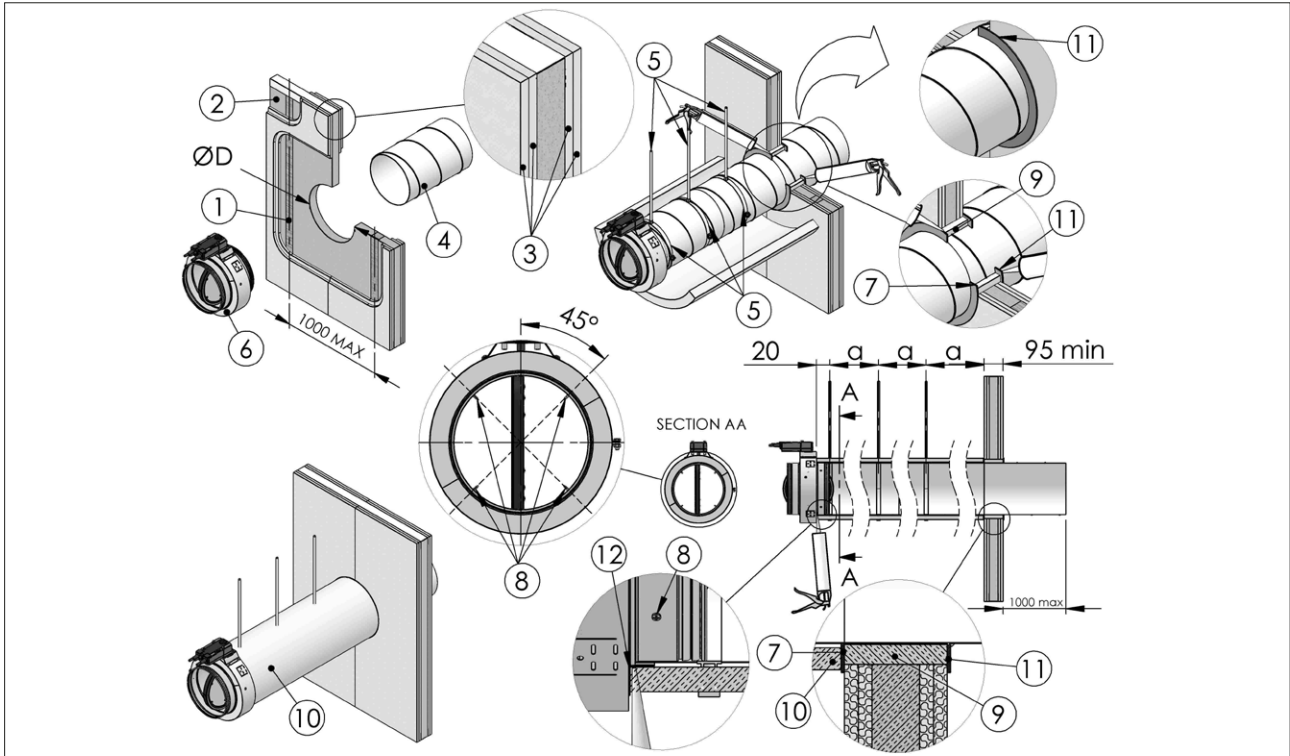

EI 60 S Installation remote from the vertical light wall hole $\varnothing+10$

- | | |
|---|--|
| <ol style="list-style-type: none"> 1. Timber studs 45 x 45 mm or metal frame 2. Rock wool density 35 kg/m³ (optional) 3. Plasterboard thickness 12,5 mm type A (EN 520) or higher 4. Ventilation duct in one piece 5. M8 threaded rod and suspension rings 6. Fire damper 7. Fire stopping sealant (reference Soudal Firecryl or equivalent with resistance and reaction to fire equal or higher) between insulation and construction support | <ol style="list-style-type: none"> 8. Self-drilling screw $\varnothing 4,2 \times 13 \text{ mm} \times 4$ 9. Insulation rock wool Pro Wired Mat 80 AL 1 Paroc or equivalent: see Installation remote from vertical light wall (plasterboard) p. 24 10. Fire stopping sealant (reference Soudal Firecryl or equivalent with resistance and reaction to fire equal or higher) between insulation and refractory ring <p>D Hole size: see table above
 a 1000mm MAX, n° of threaded rods depending on the length of the duct (use 1 threaded bar for $a \leq 1000 \text{ mm}$)</p> |
|---|--|

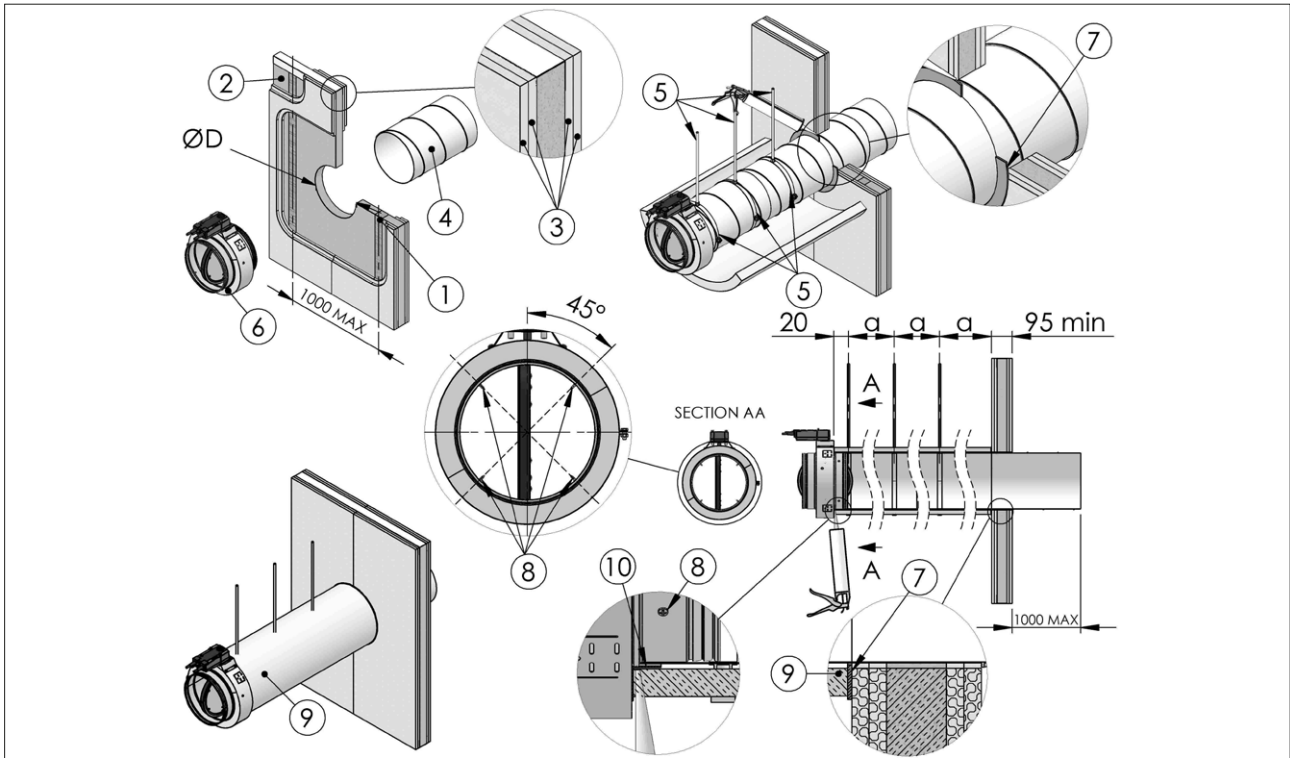

3.14. Installations remote from the floor

Refer to the section Construction supports characteristics [p.14](#) for further information.

Comply with the minimum distances indicated on section Minimum distances [p.13](#).

Before and after installation please perform a functional test. Refer to section Mechanism type for further information [p.7](#).

3.14.1. Floor opening

A opening must be provided in the floor as indicated in the drawing.

3.14.3. Filling

Fill the space between the floor and the damper as indicated in the drawing.

Sealing with concrete is not allowed.

Cover the duct over its entire length and fire damper as indicated in the drawing wrapping it with insulation rock wool Pro Wired Mat 80 AL 1 Paroc with density of 80 kg/m³ and thickness 70 mm or equivalent.

1. Ventilation duct in one piece
2. Angular fixing plate x3. Each plate fixed with 3 screws 4,2x13 mm on the duct (2.1) and 1 screw M8x40 mm with flush anchors on the floor (2.2)
3. Fire damper
4. Fire stopping sealant (reference Soudal Firecryl or equivalent with resistance and reaction to fire equal or higher) to cover the sealing
5. Self-drilling screw Ø 4,2 X 13 mm x4
6. Rock wool 35 kg/m³, or mortar or plaster putty

3.14.2. Damper positioning

Connect fire damper to the galvanized steel duct as indicated in the drawing.

Install the damper with the mechanism facing away from the wall as indicated in the drawing.

The fire damper has to be fixed and suspended from the ceiling as indicated in the drawing.

Close the blade before installing the fire damper.

A metallic mesh is installed around the rock wool. The junctions between the insulation and the damper are made by an acrylic fire stopping sealant (es. Soudal Firecryl or equivalent with resistance and reaction to fire equal or higher), as indicated in the drawing.

7. Insulation rock wool Pro Wired Mat 80 AL 1 Paroc or equivalent: see Installations remote from the floor [p.27](#)
8. Fire stopping sealant (reference Soudal Firecryl or equivalent with resistance and reaction to fire equal or higher) between insulation and sealing
9. Fire stopping sealant (reference Soudal Firecryl or equivalent with resistance and reaction to fire equal or higher) between insulation and refractory ring
- D from nominal diameter min + 30 to nominal diameter max + 55

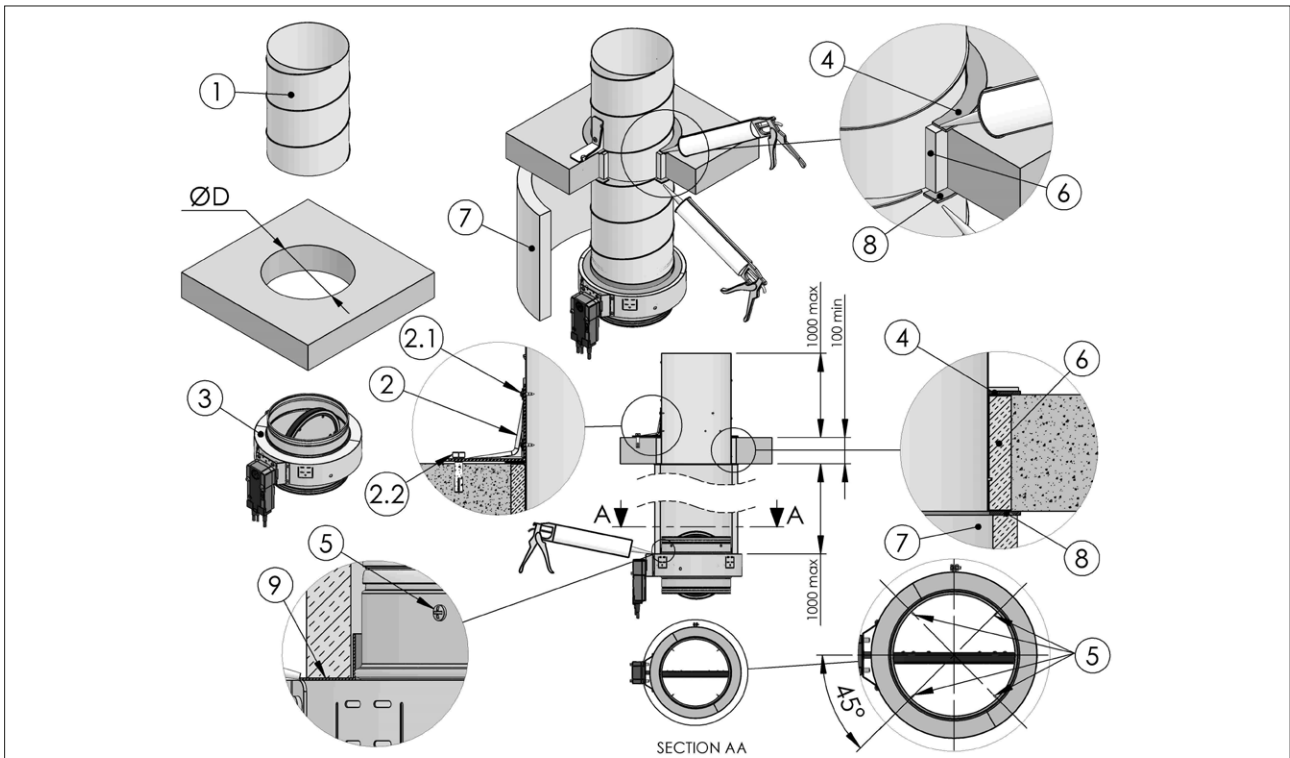

4. ELECTRICAL CONNECTIONS

4.1. Electrical wiring

Electrical connections must be done by qualified and trained people.

Switch off the power supply before starting any work on the electric elements. Never switch on the power supply during electrical connections.

4.1.1. Motorized version

Belimo servomotor:

BFL24T, BFL230T

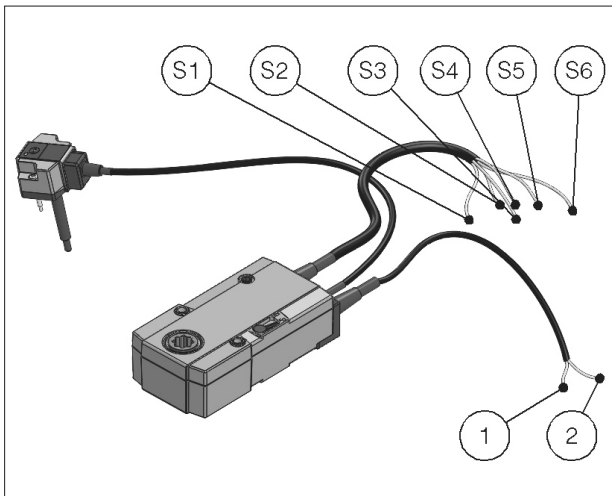

Siemens servomotor:

GRA126

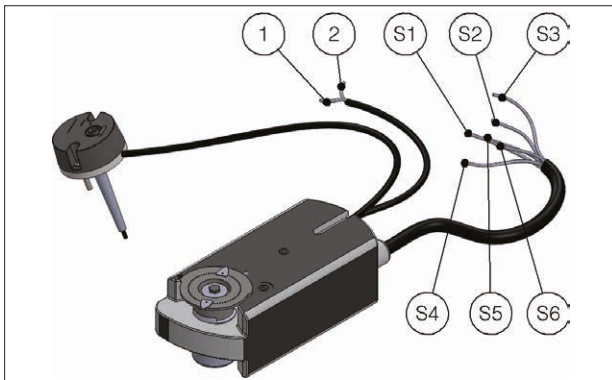

Siemens servomotor:

GRA326

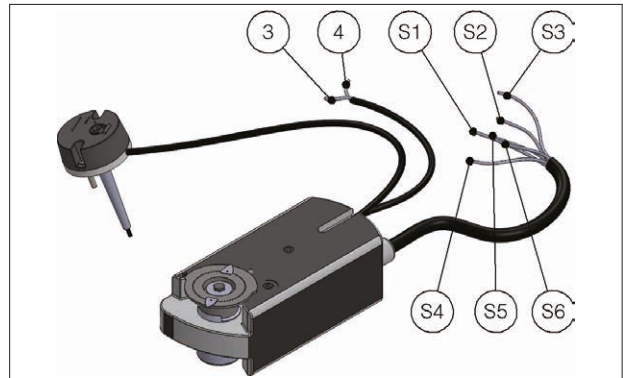

Motorized fire dampers electrical wiring

To connect the dampers to the power supply, proceed as follows:

- Check that the voltage and electrical frequency are equivalent to those of the motor of the servomotor (check the motor's information label);
- Make the connections as shown in the below diagram.

Electrical wiring for motorized version

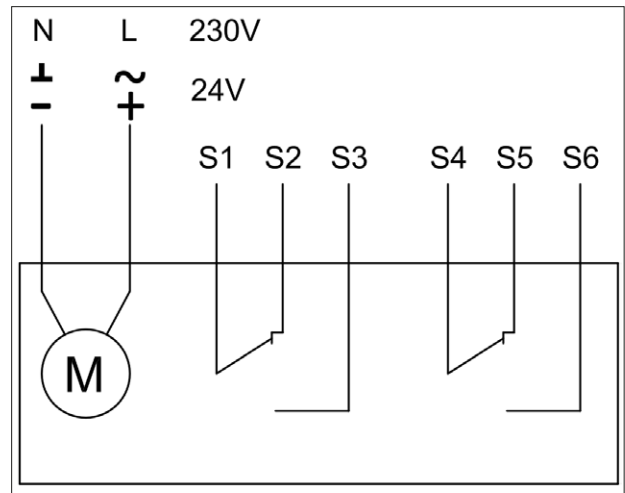

24V AC/DC power supply

- /- Negative (DC) or neutral (AC) black wire

~/+ Positive (DC) or phase (AC) red wire

230V AC power supply

N Neutral blue wire

L Phase brown wire

Microswitches position contacts

S1 Common closed damper microswitch

S2 Normally closed, closed damper microswitch

S3 Normally opened, closed damper microswitch

S4 Common open damper microswitch

S5 Normally closed, open damper microswitch

S6 Normally opened, open damper microswitch

Electrical wiring for Belimo BFL24-SR-T modulating motorized version

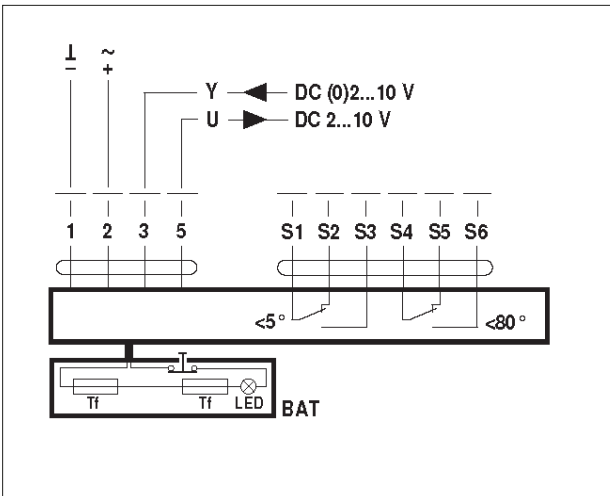

24V AC/DC power supply

I/- Negative (DC) or neutral (AC) black wire

~/+ Positive (DC) or phase (AC) red wire

3 Positioning signal Y

5 Positioning feedback U (max 0,5mA)

Microswitches position contacts

S1 Common closed damper microswitch

S2 Normally closed, closed damper microswitch

S3 Normally opened, closed damper microswitch

S4 Common open damper microswitch

S5 Normally closed, open damper microswitch

S6 Normally opened, open damper microswitch

Tf Thermal fuse

4.2. Electrical specifications

	Belimo motorized version	Siemens motorized version
Voltage and power consumption	Motor 24V AC/DC: Belimo BFL24T Opening: 2,5 W In stand-by: 0,8 W	Motor 230V AC: Belimo BFL230T: Opening: 3,5 W In stand-by: 1,1 W
	Motor 24 V AC: Siemens GRA126 Opening: 3,5 W In stand-by: 2 W	Motor 230V AC: Siemens GRA326 Opening: 4,5 W In stand-by: 3,5 W
Microswitches position contacts	Motorized version: Siemens: AC 24 V...230 V / 6 (2) A Belimo: DC 5 V... AC 250 V / 1 mA...3 A (0,5 A)	
Blade closing time	motor: < 30 s	
Protection degree	IP54 MOTORIZED VERSION	

5. MAINTENANCE AND INSPECTIONS

Fire dampers and control mechanisms do not require routine maintenance.

Extraordinary maintenance (repairs) and periodic inspection operations are the responsibility of the ventilation system operator.

It is recommended to keep enough space (about 200mm) for using or replacing the control mechanism or for maintenance. Also provide the necessary space to remove the ventilation duct from the damper whenever necessary.

It is recommended to provide inspection hatches on both sides of the ducts connected to the fire damper.

The implementation of a periodic inspection plan allows to guarantee the efficiency and functionality of the fire dampers for the fire safety of the building.

5.1. Periodic inspection and cleaning

Periodic inspection shall be performed in accordance with the requirements of the law or by the building regulations or other local regulations.

In the absence of specific regulations (or to their complement), in accordance with point 8.3 of the EN 1560 standard, it is recommended to carry out the following control activities at intervals of no more than 12 months:

- Check the servomotor electrical wiring for damage (where applicable);
- Check end-switch wiring for damage (where applicable);
- Check damper cleanliness and clean where necessary;
- Check the condition of blades and seals, rectify and report where necessary;
- Check the correct opening and closing of the fire damper by manual operation according to the instructions in the technical manual of the fire damper;
- Check the opening and closing operation of the damper controlled by the fire alarm system (if present);
- Check the operation of the end switches in open and closed state, adjust and report if necessary;
- Confirm that the damper fulfils its function as part of the control system (where necessary);
- Check that the damper is left in its normal operating position, which usually corresponds to the open position.

5.2. Repair

For safety reasons, repair activities involving fire-fighting components must be carried out only by qualified personnel.

Only original spare parts supplied by the fire damper manufacturer must be used.

A functional test must be performed after each repair.

At the end of the inspection, cleaning or repair operations, check that the fire damper is in the normal operating position.

Keep records of all inspections, repair activities, any problems encountered and their resolution.

This practice, even when not mandatory, is very useful in practice.

5.3. Disposal

Disposal in case of destruction must be carried out in accordance with national legislation. For electrical and electronic parts also refer to EU Directive 2011/65.

6. SELECTION

6.1. Air flow rates in relation to the diameter

Maximum frontal air speed = 12 m/s

\emptyset	Front section	Net section	Maximum air flow	Maximum air flow
mm	m ²	m ²	m ³ /h	l/s
100	0,008	0,006	339	94
125	0,012	0,010	530	147
160	0,020	0,017	868	241
200	0,031	0,027	1356	377
250	0,049	0,044	2120	589
315	0,078	0,071	3365	935
400	0,126	0,117	5426	1507

6.2. Air flow rates as a function of the pressure drop

\emptyset	ΔP 3 Pa		ΔP 6 Pa		ΔP 9 Pa	
	Q	Lw	Q	Lw	Q	Lw
mm	m ³ /h	dB(A)	m ³ /h	dB(A)	m ³ /h	dB(A)
100	49	13,0	69	21,8	85	27,1
125	114	17,9	161	26,4	197	31,4
160	229	16,8	324	26,3	396	31,8
200	404	19,2	571	29,0	700	34,9
250	684	26,1	967	34,7	1185	39,7
315	1536	28,8	2172	39,1	2660	45,1
400	3003	40,6	4247	49,0	5202	53,9

6.3. Air flow rates as a function of generated sound levels

\emptyset	Lw 30 dB(A)		Lw 35 dB(A)		Lw 40 dB(A)	
	Q	ΔP	Q	ΔP	Q	ΔP
mm	m ³ /h	Pa	m ³ /h	Pa	m ³ /h	Pa
100	95	11,0	115	17,0	140	25,0
125	186	8,0	228	12,0	280	18,0
160	371	8,0	445	11,0	534	16,0
200	591	6,0	703	9,0	838	13,0
250	800	4,0	979	6,0	1198	9,0
315	1597	3,0	1891	5,0	2238	6,0
400	1933	1,0	2378	2,0	2927	3,0

6.4. Pressure drop and sound level graph

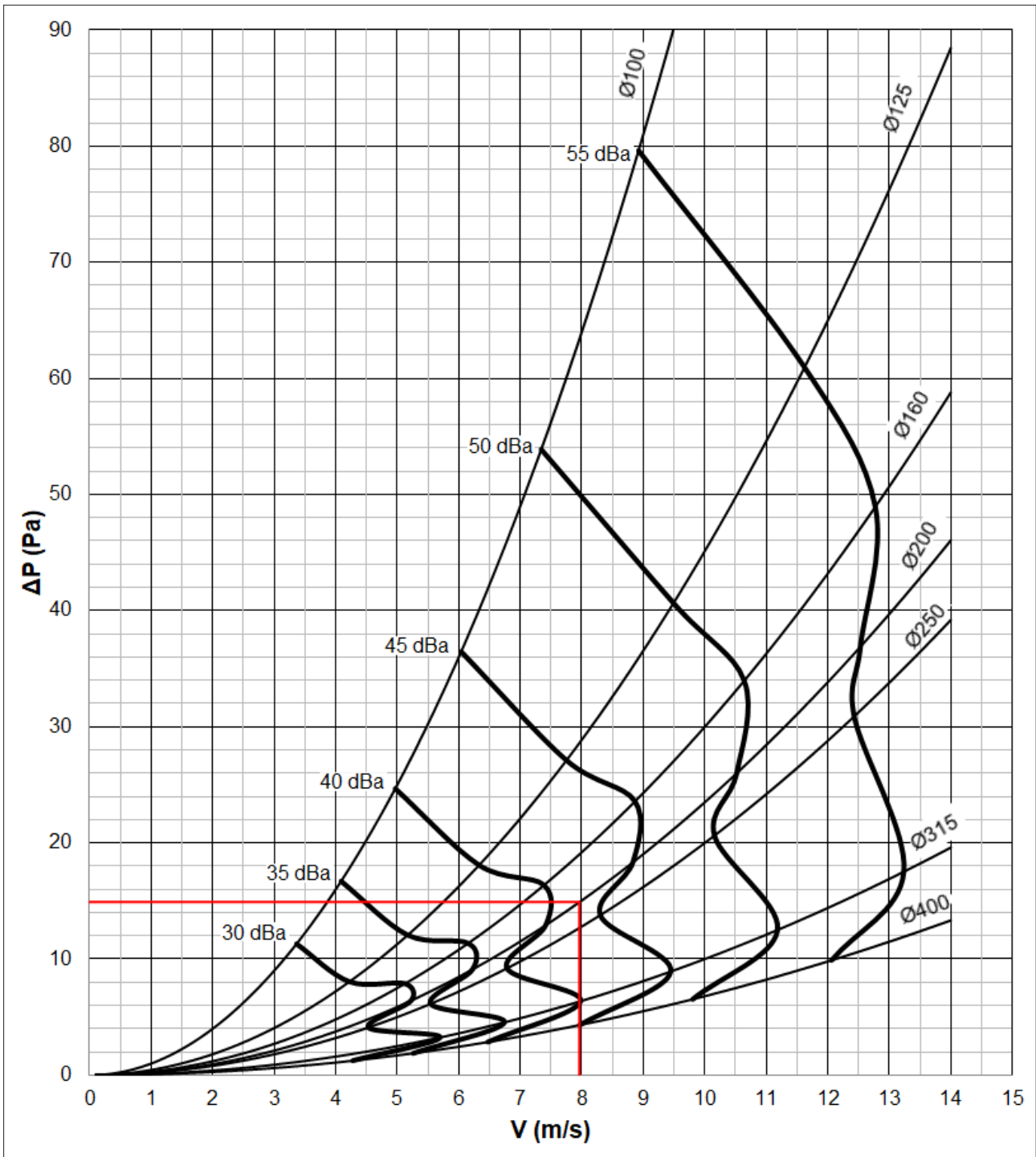

Example

Ø = Diameter [mm]	Ø = 200 mm
Q = Air flow [m ³ /h]	Q = 900 m ³ /h
V1 = Frontal air speed [m/s]	V1 = 8 m/s
ΔP = Pressure drop [Pa]	From graph: ΔP = 15 Pa
Lw = Sound level [dB(A)]	From graph: Lw = 38 dB(A)

6.5. Sound spectrum table

Correction used to estimate the octave band spectrum (Values to be added to the noise levels in dB(A))

Ø100

Hz	Speed (m/s)					
	2	4	6	8	10	12
63	16,2	10,3	6,9	4,4	2,5	1
125	7,9	5,1	3,5	2,3	1,4	0,7
250	4	3,7	3,6	3,5	3,4	3,3
500	-1,4	-1,8	-2	-2,2	-2,4	-2,5
1000	-7,2	-6,8	-6,5	-6,3	-6,2	-6,1
2000	-17,5	-14,6	12,9	-11,6	-10,7	-9,9
4000	-37,6	-28,5	-23,1	-19,4	-16,4	-14
8000	-44,4	-36,3	-31,6	-28,3	-25,7	-23,6

Ø125

Hz	Speed (m/s)					
	2	4	6	8	10	12
63	15,8	12,3	10,2	8,8	7,6	6,7
125	4,2	3,3	2,7	2,3	2	1,8
250	3,7	2,6	2	1,5	1,2	0,9
500	-0,3	-1,3	-1,8	-2,2	-2,5	-2,8
1000	-5,7	-6,2	-6,4	-6,6	-6,8	-6,9
2000	-17,3	-13,4	-11,1	-9,5	-8,2	-7,2
4000	-34,2	-24,4	-18,7	-14,6	-11,5	-8,9
8000	-27,7	-24,5	-22,6	-21,2	-20,1	-19,3

Ø160

Hz	Speed (m/s)					
	2	4	6	8	10	12
63	20,6	14	10,1	7,4	5,3	3,6
125	14,1	8,1	4,5	2,1	0,1	-1,5
250	5,9	3,2	1,6	0,5	-0,4	-1,1
500	-1,2	-2,8	-3,6	-4,3	-4,7	-5,1
1000	-7,1	-6,2	-5,7	-5,3	-5	-4,7
2000	-19,3	-14,3	-11,4	-9,3	-7,7	-6,4
4000	-30,7	-22,5	-17,6	-14,2	-11,5	-9,4
8000	-17,8	-18,5	-18,9	-19,2	-19,5	-19,7

Ø200

Hz	Speed (m/s)					
	2	4	6	8	10	12
63	17,3	12,9	10,2	8,4	7	5,8
125	10,2	6,1	3,7	2,1	0,7	-0,3
250	4,2	1,3	-0,4	-1,6	-2,5	-3,3
500	-2,9	-3,8	-4,3	-4,6	-4,9	-5,1
1000	-4,9	-4,7	-4,5	-4,4	-4,3	-4,2
2000	-17,9	-13,3	-10,6	-8,7	-7,3	-6
4000	-24,8	-18,8	-15,4	-12,9	-11	-9,5
8000	-46,3	-34,3	-27,3	-22,4	-18,5	-15,4

Ø250

Hz	Speed (m/s)					
	2	4	6	8	10	12
63	2,1	5,1	6,8	8	9	9,7
125	-3,8	-1,3	0,2	1,3	2,1	2,8
250	-5,5	-3,8	-2,8	-2,1	-1,5	-1,1
500	-6,8	-5	-4	-3,2	-2,7	-2,2
1000	-2	-3,5	-4,4	-5,1	-5,5	-6

	Speed (m/s)					
2000	-11,2	-9,6	-8,7	-8	-7,5	-7
4000	-4,5	-8,6	-11	-12,7	-14	-15,1
8000	-23	-22,1	-21,6	-21,2	-20,9	-20,6

Ø315

	Speed (m/s)					
Hz	2	4	6	8	10	12
63	16,3	11,1	8,1	5,9	4,3	2,9
125	7,9	4,5	2,4	1	-0,1	-1
250	4,6	1	-1,1	-2,5	-3,7	-4,6
500	1,5	-1,8	-3,7	-5,1	-6,1	-7
1000	-3,2	-4,3	-4,9	-5,4	-5,7	-6
2000	-14,2	-10,9	-8,9	-7,6	-6,5	-5,6
4000	-25,6	-19,6	-16,1	-13,6	-11,7	-10,1
8000	-98,4	-63,1	-42,5	-27,8	-16,5	-7,2

Ø400

	Speed (m/s)					
Hz	2	4	6	8	10	12
63	6,1	4,6	3,8	3,2	2,7	2,3
125	-13,8	-9,1	-6,3	-4,3	-2,8	-1,6
250	-14,4	-10,8	-8,7	-7,2	-6,1	-5,1
500	-2,2	-1,9	-1,7	-1,6	-1,5	-1,4
1000	-2,6	-3,9	-4,7	-5,2	-5,6	-5,9
2000	-14	-11	-9,2	-8	-7	-6,2
4000	-27,6	-20,7	-16,6	-13,8	-11,5	-9,7
8000	-43,7	-32,8	-26,3	-21,8	-18,2	-15,3

7. ACCESSORIES AND SPARE PARTS

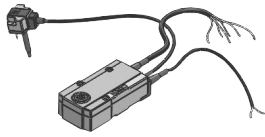

Belimo motor for dampers predisposed for use with BFL24T, 24 V AC/DC power supply, thermofuse 72 °C BFL24T
 Belimo motor for dampers predisposed for use with BFL24T-ST, 24 V AC/DC power supply, thermofuse 72 °C with connection plugs for control and monitoring systems BFL24T-ST
 Belimo motor for dampers predisposed for use with BFL230T, 230 V AC power supply, thermofuse 72 °C BFL230T

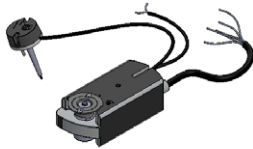

Siemens motor for dampers predisposed for use with GRA126, 24 V AC/DC power supply thermofuse 72 °C GRA126
 Siemens motor for dampers predisposed for use with GRA326, 230 V AC power supply, thermofuse 72 °C GRA326



Thermofuse 72 °C for Belimo motor BFL and BFN (spare part) WWEZBAT72
 Thermofuse 95 °C for Belimo motor BFL and BFN (accessory) WWEZBAT95
 Thermofuse 72 °C for Siemens motors GRA, GNA and GGA (spare part) MT-FUSASK79.4
 Thermofuse 95 °C for Siemens motors GRA, GNA and GGA (accessory) MT-FUSASK79.5



Communication and control unit BKS24-1B to control and monitor 1 fire damper with Belimo motor WHBKS241B



Communication and control unit BKS24-9A to control and monitor up to 9 fire dampers with Belimo motor WHBKS249A



Communication and power supply unit: BKN230-24 for Belimo motors BFL24T-ST, BFN24T-ST e BF24T-ST WHBKN23024
 Modbus Communication and power supply unit: BKN230-24MOD for Belimo motors BFL24T-ST, BFN24T-ST and BF24T-ST WHBKN230-24MOD
 Communication and power supply unit MPBUS for BKS24-9A or gateways Belimo UK24MOD and UK24BAC: BKN230-24-C-MP for Belimo motors BFL24T-ST, BFN24T-ST and BF24T-ST WHBKN230-24-C-MP
 Modbus Communication and power supply unit: BKN230MOD for Belimo motors BFL230T, BFN230T and BF230T WHBKN230MOD



Gateway UK24BAC Belimo for BACnet communication WHKUK24BAC

90° 2 holes angle connector 45x48mm

TS11



90° 3 holes angle connector 45x88mm

TS12



8. HOW TO ORDER

8.1. Motorized fire dampers

Code		
Type	FNC	Circular fire damper
Series	1	EI 60 S
Connection	U	Lindab Safe gasket
Motor type	S24	Siemens motor GRA126 (24V)
	S230	Siemens motor GRA326 (230V)
	B24	Belimo motor BFL24T (24V)
	B230	Belimo motor BFL230T (230V)
	B24R	Belimo motor BFL24-SR-T (24V) modulating
Dimension	XYZ	Nominal diameter (mm)

8.2. Fire dampers

Examples	Code
FNC1 Belimo motorized 24V fire damper, Ø 200	FNC1UB24-200

8.3. Electric motor driven actuators

Motor type	Diameters						
	100	125	160	200	250	315	400
Belimo	S	S	S	S	S	S	S
Siemens	S	S	S	S	S	S	S

	Belimo		Siemens	
	24 V	230V	24 V	230V
S	BFL24T/BFL24-SR-T	BFL230T	GRA126	GRA326

9. SPECIFICATION TEXT

9.1. Series FNC1 circular fire damper

Description

FNC1 circular fire damper tested for fire resistance and smoke seal with 300 Pa depression as per EN 1366-2, classified according to EN 13501-3 and CE marked according to European Regulation UE 305/2011 and EN 15650 standard. Allows maximum safety for fire protection inside buildings providing perfect heat insulation and cold and hot smokes tightness. Can be connected to fire protection alarm system or smokes detection to anticipate blade closure before fire, prevents indirect damages caused by smokes generated by combustion.

Technical characteristics

- Available diameters from 100 to 400 mm
- Casing made from galvanized sheet steel equipped with Lindab Safe duct connection gaskets.
- Closing mechanism with thermal fuse certified to ISO 10294-4, test button to check the correct working of the damper, a release system to block the damper in closed position and a visual signal "open/closed".
 - with electric release and rearming, via and integrated Siemens or Belimo system tested according to EN 15650, composed by an electric thermal fuse and remote controlled servomotor via an electrical signal
- Blade damper made from insulating material, rotating on steel gudgeon pins, complete with lip gasket for the air seal of cold smoke, as per EN 1366-2
- Thermal, expanding graphite gasket
- Thermal fuse with melting point certified ISO 10294-4 at 70 °C or 95 °C (version with mechanical release) or at 72 °C (version with servo motor)
- Absence of thermal bridge between the wall of installation and the ducts before and after
- Resistance to salt spray, tested with severity 2, according to EN 60068-2-52
- Casing leakage Class C according to EN 1751

Installation

- Installation within and remote from vertical rigid walls made from aerated concrete blocks, standard concrete or masonry minimum thickness 95 mm and EI 60 resistance class
- Installation within and remote from light plasterboard walls with minimum thickness of 95 mm
- Installation within and remote from concrete floors with a minimum thickness of 100 mm and minimum density of 550 kg/m³
- Fire resistance characteristics independent from direction of the source of the fire according to EN 1366-2 article 6.2
- Installation possible with damper blade placed horizontally or vertically, with the mechanism placed in left/right or above/below

Accessories

- Motorised version with 24 V or 230 V servomotor installed on the damper

- Set of microswitches with three NO/NC position detecting connectors for open and closed damper, as per standard UNI 10365
- Power supply and communication unit MP-Bus, Modbus, Bacnet

10. REVISION INDEX

Revision n°	Date of issue	Description
20/02	2020/02	First issue
		Added section: <ul style="list-style-type: none">• Installation remote from construction support p. 6• Minimum distances for remote installation from vertical wall/floor p. 13• Installation remote from the rigid wall p. 21
20/05	2020/05	<ul style="list-style-type: none">• Installation remote from the vertical light wall (plasterboard) p. 24• Installations remote from the floor p. 27 Updated drawing: <ul style="list-style-type: none">• Dimension p. 8 General improvements
20/12	2020/12	Updated section: <ul style="list-style-type: none">How to order p. 37Electrical connections p. 28Installation p. 9 General improvements

As the manufacturer is constantly improving its products, the aesthetic or dimensional features, the technical data, the equipment and accessories indicated could be subject to variations.



Via G. La Pira 9 A/B 35012 - Camposampiero (PD) - Italia
phone 049 9303516 – fax 049 9317070 – www.mp3-italia.it

