

Series
VENTS Enave 210 / 270 V



Heat recovery air handling units in sound- and heat-insulated casings.
Air flow up to **304 m³/h**.
Heat recovery efficiency up to **92 %**

■ **Fans**

Units' fans are equipped with electronically commutated motors.

■ **Heat Exchanger**

Enave units are equipped with a counter-flow polystyrene heat exchanger.

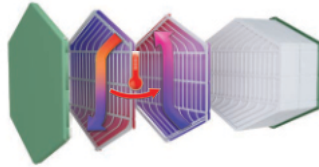

Enave-T units are equipped with an enthalpy heat exchanger.

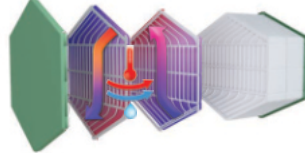

■ **Bypass**

Units are equipped with a bypass for summer cooling.

■ **Automation**

Enave V A21 units are equipped with a built-in automation system. The **A21** controller allows to integrate the unit into the **Smart Home system** or **BMS (Building Management System)**. To control the unit via Wi-Fi, download the **Vents Home** smartphone app.

Enave V A14 units have an integrated control system with a wall-mounted control panel equipped with LED indication.



Google play



Download on the App Store







■ **Frost protection**

For **Enave V** units the frost protection is realized by shutting down the supply fan. Optional duct pre-heater is available for units with A21 control system.

■ **Mounting**

The unit is designed for wall and floor mounting. The mounting position of the unit must provide service access for maintenance and repair.

■ **Control and automation**

Functions	A21	A14
Wired remote control panel	A22 (option) 	A14 
Control via a wired remote LCD control panel	A25 (option) 	-
Wireless remote control panel	A22 Wi-Fi (option) 	-
BMS	ModBus RTU (RS-485) ModBus TCP/IP (Wi-Fi, Ethernet)	-
Vents Cloud Server service	+	-
Control via Wi-Fi using a smartphone app	+	-
Frost protection	+	+
Bypass	Auto, manual	Manual
Week-scheduled operation	+	-
Filter replacement indication	Filter timer	+
Alarm indication	+	+
Speed selection	+	+
Timer	+	-
RH% sensor	Option	Option
CO ₂ sensor	Option	Option
VOC sensor	Option	Option
PM2.5 sensor	Option	Option
Boost mode	+	-
Fireplace mode	+	-
Preheater connection	+	-
Reheater connection	+	-
Cooler connection	+	-
Fire alarm sensor connection	+	+
Minimum supply air temperature control	+	-

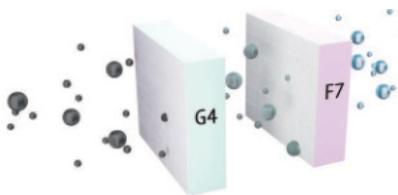

Designation key

TM	Model	Heat exchanger type	Nominal size	Modification	Casing type	Heater	Control system	Version
VENTS	Enave	_ – heat recovery T – energy recovery	Air flow m ³ /h / 10	0 – standard	V - vertical	_ – w/o heater E – integrated pre-heater	A21, A14	L – left R – right

Unit design

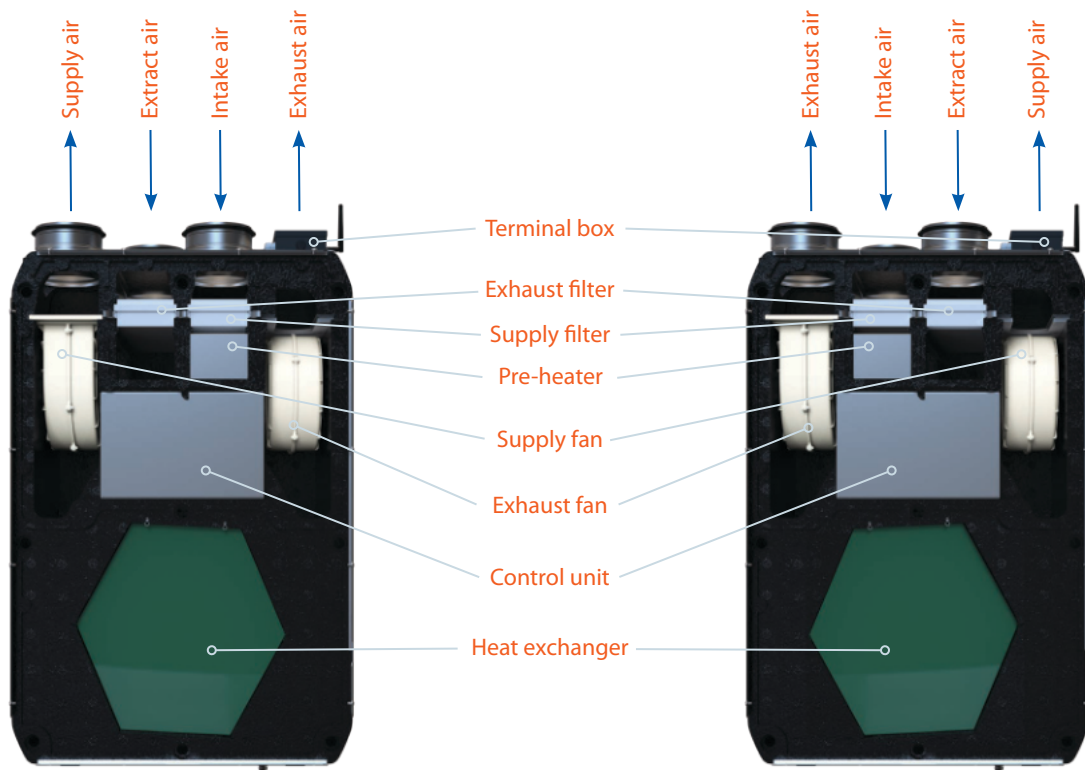

Enave 210 / 270 VL

Enave 210 / 270 VR

Overall dimensions

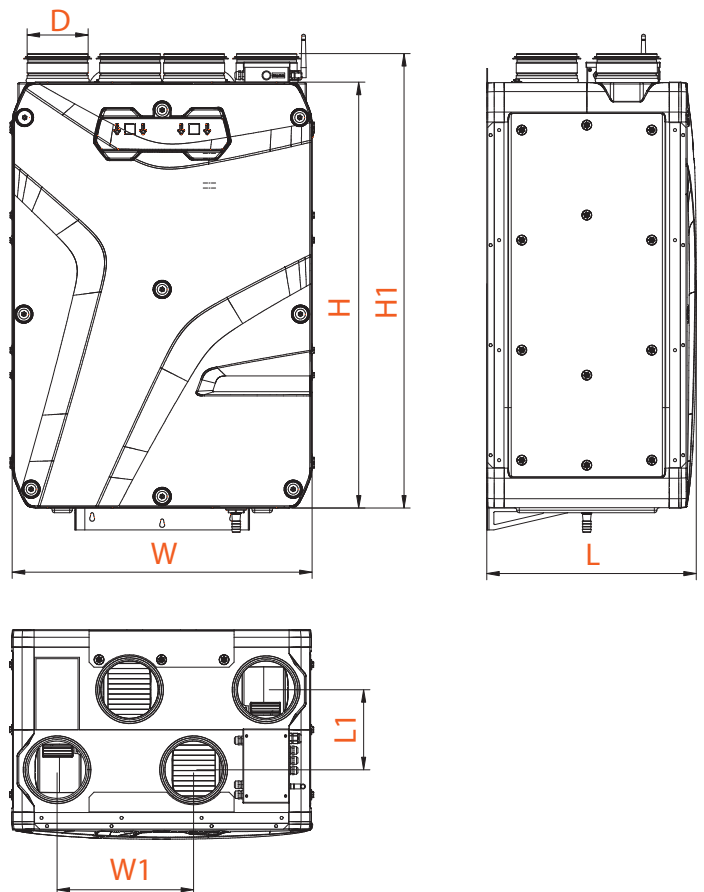
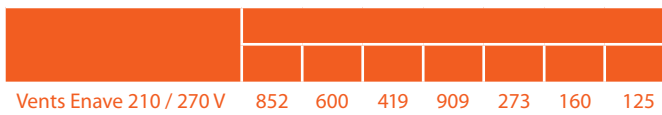





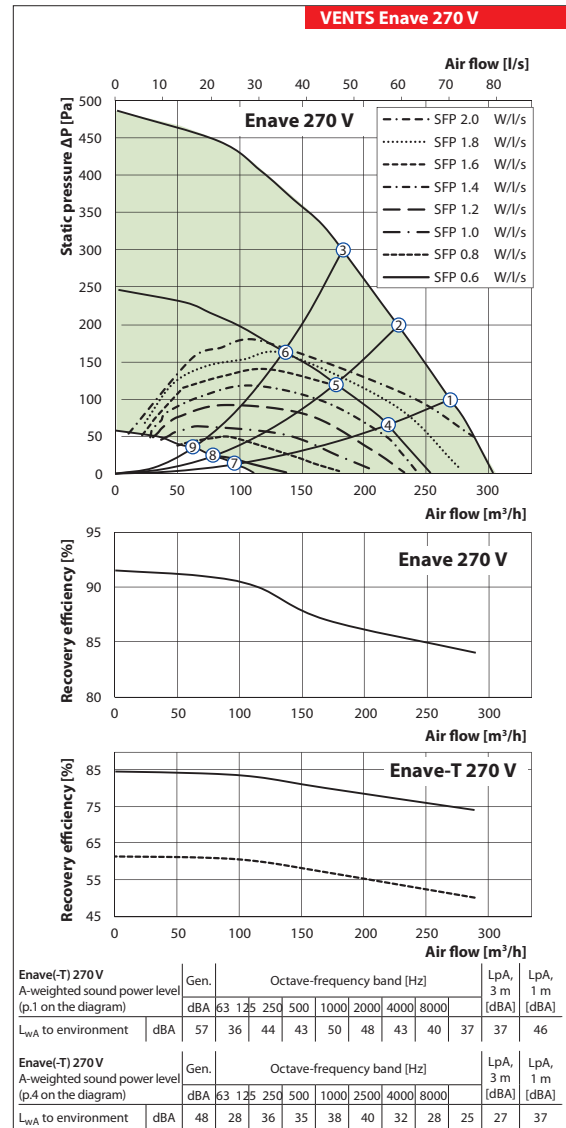
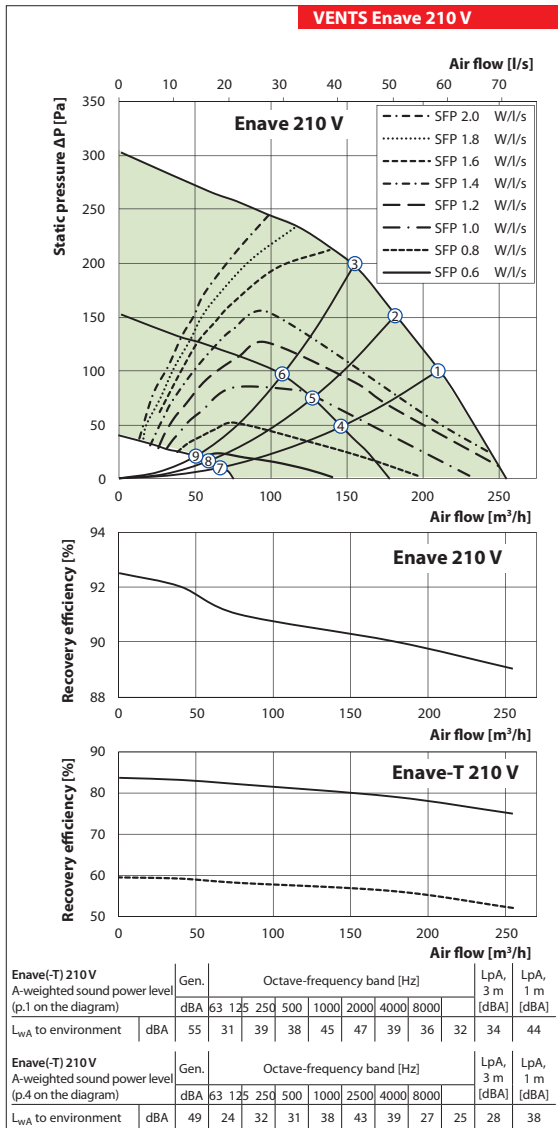

Technical data

	Vents Enave 210 V	Vents Enave-T 210 V	Vents Enave 210 VE	Vents Enave-T 210 VE	Vents Enave 270 V	Vents Enave-T 270 V	Vents Enave 270 VE	Vents Enave-T 270 VE
Voltage [V / 50-60 Hz]	230							
Max. unit power without electric heater [W]	114			176				176
Integrated electric heater power [W]	-	-	800	800	-	-	1400	1400
Max. unit power [W]	114	114	914	914	176	176	1576	1576
Max. unit current without electric heater [A]	0.92			1.34				
Integrated electric heater current [A]	-	-	3.55	3.55	-	-	6.21	6.21
Max. unit current [A]	0.92	0.92	4.47	4.47	1.34	1.34	7.55	7.55
Max air flow [m³/h]	255			304				
Sound pressure level at 3 m distance [dBA]	34			37				
Max. operating temperature [°C]	- 25...+40							
Case material	EPP							
Insulation [mm]	25							
Extract filter	G4 / Coarse > 60%							
Supply filters	G4 / Coarse > 60% (option F7 / ePM1 60%)							
Connected air duct diameter [mm]	125				22			
Weight [kg]	20			22				
Heat recovery efficiency [%]	92	83	92	83	91	84	91	84
Heat exchanger type	Counter-flow							
Heat exchanger material	Polystyrene	Enthalpy	Polystyrene	Enthalpy	Polystyrene	Enthalpy	Polystyrene	Enthalpy
SEC class	A+	A	A+	A	A	A	A	A



Accessories for air handling units

	Filter G4	Filter F7	Control panel	Control panel	Wi-Fi Control panel	Internal humidity sensor	Internal CO2 sensor
							
Enave 210 V A21	SF 356x100x48 Coarse 90% G4	SF 356x100x48 ePM1 65% F7	A25	A22	A22 Wi-Fi	HV2	CO2-3
Enave-T 210 V A21							
Enave 210 VE A21							
Enave-T 210 VE A21							
Enave 270 V A21							
Enave-T 270 V A21							
Enave 270 VE A21			-	-	-		
Enave-T 270 VE A21							
Enave 210 V A14							
Enave-T 210 V A14							
Enave 270 V A14							
Enave-T 270 V A14							

	External CO2 sensor with indication	External CO2 sensor	External humidity sensor	Electrical preheater	Electrical reheater	Syphon kit	Silencer	Air damper	Electric actuator
									
Enave 210 V A21	CO2-1	CO2-2	HR-S	NKP 125 A21 V.2	NKD 125 A21 V.2	SH-32	SR 125	KRV 125	TF 230
Enave-T 210 V A21									
Enave 210 VE A21									
Enave-T 210 VE A21									
Enave 270 V A21									
Enave-T 270 V A21									
Enave 270 VE A21				-	-				
Enave-T 270 VE A21									
Enave 210 V A14									
Enave-T 210 V A14									
Enave 270 V A14									
Enave-T 270 V A14									